

Phasing out lead in solders:

An assessment of possible impacts of material substitution in
electronic solders on the recycling of printed circuit boards

Ulrika Kindesjö

Supervisors

Don Huisingh, Håkan Rodhe

Thesis for the fulfilment of the
Master of Science in Environmental Management and Policy
Lund, Sweden, October 2002

© You may use the contents of the IIIIEE publications for informational purposes only. You may not copy, lend, hire, transmit or redistribute these materials for commercial purposes or for compensation of any kind without written permission from IIIIEE. When using IIIIEE material you must include the following copyright notice: 'Copyright © IIIIEE, Lund University. All rights reserved' in any copy that you make in a clearly visible position. You may not modify the materials without the permission of IIIIEE.

Published in 2001 by IIIIEE, Lund University, P.O. Box 196, S-221 00 LUND, Sweden,
Tel: +46 – 46 222 02 00, Fax: +46 – 46 222 02 10, e-mail: iiiiee@iiiiee.lu.se.
Printed by KFS AB, Lund.

ISSN 1401-9191

Acknowledgements

I would like to thank everyone that participated and contributed to the outcome of this thesis. Many people have directly or indirectly, through showing interest in the issue addressed in this thesis and through supporting me in my research in various ways, contributed to the outcome of this thesis. Without you, this thesis would not have been in its present form.

First of all I would like to thank everyone at the Center for Clean Products and Clean Technologies, University of Tennessee, who gave me the opportunity to take part of your project and to look into a very interesting research area. You welcomed me to Knoxville, with open arms and I will never forget the good spirit of our project group. Maria, thank you for all the support and for showing me some of the environment outside the walls of the office. Jack, thank you for all the, sometimes intense, discussions we had, I will surely miss them. Brooke and Sarah, thank you for the good work and for giving me some experience of the student life at the University of Tennessee. Sarah, I will never forget how we together struggle to find data, in an ocean of information gaps.

I also would like to thank my supervisors, Don Huisingsh and Håkan Rodhe. Without you Don, this thesis would never have been possible. I also wish to thank you Don for giving me the opportunity to visit Boliden's copper smelter in Rönnskär, Sweden.

Appreciation is extended to all people who answered my questions and provided me with valuable information and support me in my research. I especially wish to thank Theo Lehner (Boliden) and Anders Axelsson (Arvamet) for letting me come and visit you in Skellefteå and for showing me how EEE waste is treated, in practise.

A special thanks to everyone at the IIIIEE and especially to my batch, the 7th batch, for participating and making this year into a unique, challenging and rewarding experience. Last but not least, I would like to thank Johan for always being there.

Abstract

The electronics industry is currently facing increasing legislative and international market pressures to phase out the use of lead-based solders in favour of alternative lead-free solders.

In June 2001, the European Commission adopted a draft directive on the Restriction of the use of certain hazardous substances in Electrical and Electronic Equipment (RoHS). This directive, which among other things states that the Member States shall ensure that lead in electronic solders is banned by 2006, has been highly debated among the whole global electronics industry. Opponents of the RoHS directive have questioned the validity of the decision to phase out lead in solders, as the directive excludes today's biggest usages of lead, e.g., batteries, various oxides, ammunition etc. Another argument against the decision is that it is not based on any risk assessment and thus, there is the risk that lead currently used in solders could actually be substituted with metals that might impose as big or even bigger environmental impacts.

In light of the questions that still remain concerning the environmental benefits of substituting lead in solders, this thesis looks at the waste management of electrical and electronic equipment (EEE) and assesses the possible impacts that the substitution of lead in solders might have on recycling of printed circuit boards (PCBs). Four technically viable lead-free solder alternatives, i.e., tin-copper (99.3 Sn/0.7 Cu), tin-silver-copper (95.5 Sn/4.0 Ag/0.5 Cu), tin-silver-bismuth (42 Sn/1.0 Ag/57 Bi) and tin-silver-copper-bismuth (92.3 Sn/3.4 Ag/1.0 Cu/3.3 Bi) are compared with the conventionally used tin-lead solder (63 Sn/37 Pb).

The conclusions from this research are that from a recycling perspective, the environmental and worker's health problems with lead in solders do not seem to be very extensive. Nevertheless, if substituted, silver and copper containing alloys are to be preferred as these metals can be easily recycled in today's recovery processes. More importantly, silver will, due to its monetary value, increase the economic incentives to recycle PCBs. Bismuth-containing alloys should be avoided due to the difficulty of separating copper and bismuth in the recovery process.

Executive Summary

Lead is a soft, heavy metal with a low melting point, which makes it one of the easiest metals to cast. For more than 50 years, lead-containing solders have been used throughout the electronics industry for attaching components to printed circuit boards (PCBs). These solders have been extensively used as they form reliable joints under a variety of conditions and are inexpensive. However, currently, the electronics industry is facing increasing legislative and international market pressures to phase out the use of lead-based solders in favour of lead-free solders.

During the last decade, the world focus on the end-of-life treatment of electrical and electronic equipment (EEE) has increased. The EEE industry is one of the fastest growing sectors of today's manufacturing industry. New applications of electrical and electronic products are increasing considerably, at the same time, the average replacement of these products is accelerating. These trends have resulted in dramatic increases in the generation of EEE waste. This, in turn, has resulted in increasing problems at the waste management phases. In 1998, six million tons of EEE waste were generated in the European Union (EU), with an expected annual growth rate of 3-5%. According to the Nordic Council of Ministers, more than 90% of this waste is landfilled, incinerated or recovered without any pre-treatment.

In consideration of the current waste management, and particularly concerns about the rapid growth and the hazardous content of EEE, the European Commission adopted two draft directives in June 2000 on Waste Electrical and Electronic Equipment (WEEE) and on the Restriction of the use of certain hazardous substances in Electrical and Electronic Equipment (RoHS). The latter of these two, which among other things state that the Member States shall ensure that lead in electronic solders is banned by 2006, has been highly debated among the global electronics industry. Opponents of the RoHS directive have questioned the validity of the decision to phase out lead in solders, as the directive excludes today's biggest usages of lead, e.g., batteries, various oxides, ammunition etc. Currently, lead used in electronic solders only accounts for about 0.5% of the total usage, while the major uses of lead are for batteries (80.8%); paint, glass and ceramic products, pigments and chemicals (4.8%); ammunition (4.7%); and sheet lead, cable covering, casting metals, brass and bronze (5.0%).

Another argument against the decision is that it is not based on any human health or environmental risk assessment and thus, there is a risk that lead, currently used in solders could actually be substituted with metals that might impose as big or even bigger environmental and human health impacts.

In consideration of the questions that still remain about the environmental benefits of substituting lead in solders, this thesis assesses the possible impacts a substitution of lead in solders could have on the recycling of EEE waste. Moreover, this thesis seeks to contribute to the understanding of the science behind the EU decision to phase out lead in solders. In order to do this, literature sources as well as interviews with involved actors in the recycling industry and actors involved in the decision making process on the EU level, were used. In the assessment, four technically viable lead-free solder alternatives, i.e. tin-copper (99.3 Sn/0.7 Cu), tin-silver-copper (95.5 Sn/4.0 Ag/0.5 Cu), tin-silver-bismuth (42 Sn/1.0 Ag/57 Bi) and tin-silver-copper-bismuth (92.3 Sn/3.4 Ag/1.0 Cu/3.3 Bi) were compared with the conventionally used tin-lead solder (63 Sn/37 Pb).

In order to assess the possible implications of a substitution of lead in solders on the recycling of EEE waste, the thesis author sought an answer to the question, how much solder is destined for the recycling systems currently operating? To answer this question, an assessment of the amounts of EEE waste generated and the fate of this waste stream was conducted, with a focus on PCBs that contain the solder. In general, it can be concluded that the information about EEE waste is very limited. The reporting systems for EEE waste are not well developed, and at the same time, the definition for EEE waste is not consistent among different countries, which makes it hard to get a good picture of the current situation. However, based upon the best data available, the author estimated that current

collection schemes of EEE waste correspond to collection rates of approximately 15% in the EU and 9% in the United States (U.S.).

In general, it can be said that in the recycling systems in operation today for end-of-life EEE, there is no direct focus on recycling of tin-lead solders. PCBs, which contain considerable quantities of valuable metals, are, after separation at dismantling facilities, delivered to copper smelters for the recycling of precious metals and copper. The solder, contained in the PCBs, follows the pathway of the PCBs. Currently, on the global market there are only four large copper smelters that process EEE waste containing PCBs, Boliden (Sweden), Noranda (Canada), Umicore (Belgium) and Norddeutsche Affinerie (Germany). In total, these smelters process approximately 100 000 tons of EEE waste annually, of which 50 000 tons are estimated to be pure PCBs.

The current research revealed, that at the copper smelters, most of the tin, lead and bismuth contained in the PCB fractions are “boiled” away in the process. Silver and copper are, on the other hand, refined as separate end products. Tin, lead and bismuth consequently, follow the process gases and are predominantly trapped in the cleaning devices as filter dust. At the present situation, at one site, approximately one quarter of this filter dust is subsequently sent to other smelters, where the metals contained in the dust are recovered. However, the remaining three quarters are temporarily stored onsite awaiting final disposal. Consequently, large amounts of raw material resources in today’s operation are lost in the process. From a resource point of view, it could be beneficial to substitute tin-lead solders with solders that contain more silver and copper, since they are currently more effectively recycled. However, the contents of silver and copper in the four lead-free solders, addressed in this thesis, are still very low, at the most 4.5% of the alloys, and thus, most of the lead-free solders will follow the same fate as tin-lead solders. Nevertheless, if tin-lead solders are substituted with silver-containing solders, the economic incentives for recycling PCBs will increase, as the metal price for silver is much higher than for tin and lead and thus, a substitution could have resource benefits.

From interviews with representatives from copper smelters and a site visit to Boliden’s copper smelter, concerns about bismuth, and to some extent, tin, in the smelting process were expressed. Some of the bismuth that goes into the process will end up contaminating the final copper product i.e., the copper cathodes. Since currently, the smelters cannot separate this bismuth from the cathodes, the smelter operators are keeping constant control over the amounts fed into the process by sampling all EEE waste for its content of bismuth. In the worst case, a substitution of tin-lead solders with bismuth-containing solders could result in the smelters no longer treating EEE waste.

In this thesis, most of the findings concerning the metal recovery process of PCBs are based upon the recover process run by Boliden, Sweden. Consequently, to verify how representative these findings are for all smelters, more in depth investigations of the processes run by the others should be conducted. However, based upon the finding that Boliden and Noranda use quite similar processes and that they together process approximately 80% of all PCB containing waste, the overall findings of this thesis probably give a representative picture of reality.

During the research, it was concluded that no risk assessments on lead in solders had been conducted prior to the development of the EU proposal. Instead, the decision to ban lead in solders was predominantly based upon general toxicological and eco-toxicological data about lead. Although, lead is highly toxic to both humans and the environment and should be avoided in production when possible, no major worker’s health or environmental problems, due to the lead in solders, were identified in the PCB recycling process.

Nevertheless, the probability of the ban being implemented in the EU is very high and the impact on the global electronics industry is expected to be as high. From the findings of this research, it can be concluded that from a pure recycling perspective of PCBs, the environmental, technical and economic impacts of substituting tin-lead solders with lead-free solders do not seem to be very extensive. There seems to be some negative technical impacts involved in substituting tin-lead solders with bismuth-

containing solders, in the same time as there seems to be some positive economical and indirectly environmental impacts, the latter through increased recycling rates, that could support the replacement of the tin-lead solder with tin-silver-copper or tin-copper solder systems. However, to assess whether the European Commission made a proper decision when it put forward a ban on lead in solders, further investigations of the other lifecycle stages of solders have to be conducted.

Table of Contents

List of Boxes

List of Figures

List of Tables

1. INTRODUCTION	1
1.1 BACKGROUND.....	1
1.2 PURPOSE.....	2
1.3 SCOPE AND LIMITATIONS	3
1.4 METHODOLOGY.....	3
1.4.1 <i>The Lead-Free Solder Project</i>	4
1.5 STRUCTURE OF THE THESIS.....	5
2. INTRODUCTION TO LEAD AND SOLDERS	6
2.1 LEAD PRODUCTION AND USE.....	6
2.2 ELECTRONIC SOLDER USE	7
2.3 LIFECYCLE OF SOLDER	7
2.4 APPLICATION.....	8
2.4.1 <i>Wave Soldering</i>	9
2.4.2 <i>Reflow Soldering</i>	10
2.5 PERFORMANCE REQUIREMENTS.....	10
2.6 LEAD-FREE SOLDERS.....	11
2.7 TOXICOLOGICAL AND ECOLOGICAL ASPECTS OF TIN-LEAD AND OF LEAD-FREE SOLDERS	12
2.7.1 <i>Lead</i>	12
2.7.2 <i>Tin</i>	13
2.7.3 <i>Copper</i>	13
2.7.4 <i>Silver</i>	14
2.7.5 <i>Bismuth</i>	14
3. PHASING OUT LEAD IN SOLDER.....	16
3.1 HISTORY OF PHASING OUT LEAD.....	16
3.2 ACTIVITIES TO PHASE OUT LEAD IN ELECTRONICS	18
3.2.1 <i>U.S.</i>	18
3.2.2 <i>Japan</i>	19
3.2.3 <i>Europe</i>	20
3.3 THE WASTE ELECTRICAL AND ELECTRONIC EQUIPMENT DIRECTIVE.....	21
3.4 PROPOSAL FOR A DIRECTIVE ON THE RESTRICTION OF THE USE OF CERTAIN HAZARDOUS SUBSTANCES IN ELECTRICAL AND ELECTRONIC EQUIPMENT.....	24
3.4.1 <i>The Science Behind the Decision to Phase Out Lead in Solders</i>	25
3.4.2 <i>Involved Actors</i>	26
4. RECYCLING OF PCBs/EEE WASTE.....	28
4.1 THE FATE AND AMOUNT OF WASTE OF EEE.....	28
4.1.1 <i>EU</i>	28
4.1.2 <i>The U.S.</i>	30
4.2 COLLECTION AND DISMANTLING	32
4.3 METAL RECOVERY.....	34
4.4 DESCRIPTION OF THE PROCESS OF REFINING COPPER AND PRECIOUS METALS FROM EEE	35
4.4.1 <i>Sampling</i>	37
4.4.2 <i>Smelting</i>	39
4.4.3 <i>Conversion</i>	41
4.4.4 <i>Anode casting</i>	42
4.4.5 <i>Electrolysis</i>	42

4.4.6	Precious Metal Refinery.....	42
4.5	THE FATE OF TIN-LEAD AND LEAD-FREE SOLDERS IN THE METAL RECOVERY PROCESS	43
4.6	SOLDER RECYCLING AT THE MANUFACTURING AND APPLICATION STEPS	47
5.	ANALYSIS	48
5.1	WHAT QUANTITIES OF SOLDERS ARE TREATED IN THE RECYCLING SYSTEMS IN OPERATION TODAY?	48
5.2	THE RECYCLING SYSTEM FOR EEE WASTE	50
5.2.1	Organisation	50
5.2.2	Environmental Aspects	51
5.3	POSSIBLE IMPLICATIONS OF A SUBSTITUTION OF LEAD IN SOLDERS.....	52
5.3.1	Environmental Implications.....	52
5.3.2	Technical Implications.....	54
5.3.3	Economic Implications.....	55
5.4	IMPACTS OF SUBSTITUTING LEAD IN SOLDERS ON PRE-CONSUMER SOLDERING RECYCLING	56
5.5	SUMMARY OF THE POSSIBLE IMPLICATIONS OF THE LEAD-FREE ALTERNATIVES ON WASTE EEE RECYCLING	56
6.	CONCLUSIONS AND RECOMMENDATIONS	58
6.1	RECOMMENDATIONS.....	61
	BIBLIOGRAPHY.....	63
	ABBREVIATIONS.....	68
	APPENDIX 1: EUROPEAN INITIATIVES TO DEAL WITH PROPER TREATMENT OF WASTE EEE	69
	APPENDIX 2: LIST OF BUSINESS ORGANISATIONS CONSULTED BY THE EUROPEAN COMMISSION BETWEEN 1994 AND 1999 BEFORE FINALISING THE PROPOSALS FOR THE WEEE AND ROHS.....	77
	APPENDIX 3: FLOW MAP OF THE PROCESS STEPS INVOLVED IN REFINING PRECIOUS METALS AND COPPER FROM PCBS.....	78
	APPENDIX 4: POSSIBLE FUTURE RECYCLING TECHNOLOGIES FOR THE RECOVERY OF ELECTRONIC SOLDERS	79

List of Boxes

Box 2-1. Criteria that must be fulfilled by lead-free solder alternatives.....	11
Box 3-1. The categories of electrical and electronic equipment covered by the proposed WEEE directive.....	22
Box 3-2. Minimum separation requirements for certified treatment facilities set by the WEEE directive.....	22
Box 4-1. Fate of tin-lead, tin-copper, tin-silver-copper and tin-silver-bismuth in the smelting process.....	46
Box 4-2. Fate of the tin-silver-copper-bismuth alloy in the smelting process.....	47
Box 5-1. The monetary value of one ton of PCBs, calculated based upon the content of copper, silver and gold	56

List of Figures

Figure 2-1. Percentage of lead used by the electronic solder industry.....	7
Figure 2-2. The lifecycle of electronic solder, displaying the various steps involved, from production of solder from raw materials through the end-of-life treatment of EEE containing the solders.....	8
Figure 2-3. The two most common methods for soldering components to PCBs, a) Through-Hole Technology (THT) and b) Surface Mount Technology (SMT).....	9
Figure 2-4. Process description of wave soldering with through-hole components	9
Figure 2-5. Process description of reflow soldering with surface-mount components	10
Figure 4-1. Municipal waste generated in Europe.....	30
Figure 4-2. Municipal solid waste management in the U.S. from 1960 to 2000.....	31
Figure 4-3. The main material fractions separated at Stena Technoworld, Sweden, which is a large dismantling company for EEE waste.....	33
Figure 4-4. The extracting processes for copper, lead, zinc, and precious metals at Boliden, Rönnskär.....	36
Figure 4-5. Metal recovery process of PCBs, showing the various materials in- and outflows in the different steps.....	36
Figure 4-6. Sampling of EEE waste coming into Noranda.....	37
Figure 4-7. Average material composition of PCBs, divided into the three main fractions i.e. metals, plastics and ceramics.....	39
Figure 4-8. Boliden's Kaldo furnace used to process EEE waste.....	40
Figure 4-9. The precious metal refinery process at Noranda.....	43
Figure 4-10. The fate of lead, tin, copper, silver and bismuth in Boliden's metal recovery process in Rönnskär, Sweden.....	45
Figure 5-1. Estimated fate of PCBs generated in EU.....	49
Figure 5-2. Average blood lead level (measured in μ mol Pb/litre) for the workers at Boliden, during the period from 1950 to 2000.....	52
Figure 5-3. Melting and boiling points for tin (232°C), bismuth (272°C), lead (327.5°C), silver (961°C) and copper (1 085°C).....	53

List of Tables

Table 1-1. Selected solders looked upon in this thesis	3
Table 2-1. Lead consumption divided into application areas.	7
Table 3-1. JEITA’s roadmap for Japanese electronics industry, from 2000, on the phase out of lead in electrical and electronic equipment.....	19
Table 3-2. Summary of the principal obligations for the treatment of household waste electrical and electronic equipment placed on different actors by the WEEE directive.	23
Table 4-1. Separately collected EEE waste in Sweden, since the enactment of the EPR legislation in July 2001.....	29
Table 4-2. Generation, recovery and discards of consumer electronics in the municipal waste stream in the U.S. in 2000.....	31
Table 4-3. The fate of EEE waste in the U.S., estimated based on data from 2000.....	32
Table 4-4. Threshold values for penalty and maximum allowed levels of Bi, Pb and Sn in electronic scrap that the copper smelters Boliden, Umicore and Noranda hold against their suppliers.....	38
Table 4-5. Composition of elements, by weight, contained in a PCB.....	39
Table 4-6. Emissions from the Kaldo furnace in 2001, when used for processing EEE waste.....	41
Table 4-7. Typical composition of the copper concentrate processed in Boliden’s smelter	42
Table 5-1. Amount of EEE waste generated and separately collected for recycling in different countries.....	48
Table 5-2. Metal prices and reserves for Bi, Cu, Pb, Ag and Sn	55
Table 5-3. Summary of the possible implications of subsisting tin-lead solders with the lead-free alternatives addressed in this study.....	57

1. Introduction

1.1 Background

The manufacturing industry of electrical and electronic equipment (EEE) is one of the fastest growing industry sectors in the world. New applications of EEE are increasing significantly at the same time as the average replacement process is accelerating. This trend has led to an important increase in EEE waste, which in turn results in increasing problems at the waste management stage. In 1998, six million tons of waste from EEE were generated in the European Union (EU).¹ In addition, an average annual growth rate of 3-5% is expected for EEE waste, which is about three times higher than the average growth in the generation of municipal waste.^{2, 3}

The EEE waste stream consists of a complex mixture of materials and components. The hazardous content, as well as the rapid growth of EEE, are of major concern at the waste management stage. Additionally, according to the European Commission, the EEE waste stream differs from the municipal waste stream in that the environmental burden due to its production far exceeds the environmental burden from production of other materials contained in the municipal waste stream.⁴

Concerns about environmental and worker's health risks associated with current EEE waste management have been growing during the last decade. In 1995, the Nordic Council of Ministers estimated that more than 90% of the EEE waste generated is landfilled, incinerated or recovered without any pre-treatment.⁵ This would mean that large amounts of hazardous materials are put into the disposal or recovery routes, thereby posing considerable risks to the Society and to the ecosystem. In countries like China the situation might be even worse. In February 2002, the Basel Action Network (BAN), a global network of toxics and development activities organisations with its headquarters in Seattle, Washington, USA, and the Silicon Valley Toxic Collision (SVTC), an environmental public interest group, with its headquarters in San Jose, California, USA, reported that large amounts of EEE waste collected for recycling in the United States (U.S.), which has not signed the Basel Convention, is not recycled domestically but is instead sent to destinations like China, India, and Pakistan. This EEE waste, which is supposed to be imported to be recycled, is most commonly treated using hazardous and dangerous operations such as open burning or just dumping in uncontrolled places.⁶

In consideration of the environmental and human health problems related to the production and waste management of EEE, the European Commission, adopted two proposals for directives in June 2000, i.e., the directives on Waste Electrical and Electronic Equipment (WEEE) and on the Restriction of the use of certain hazardous substances in Electrical and Electronic Equipment (RoHS). The WEEE directive gives a comprehensive framework for the management of EEE waste. Its objective is to prevent the generation of EEE wastes, increase reuse and recycling and to reduce the environmental burden associated with end-of-life treatment. Throughout The directive requires producers of EEE to take back consumer, end-of-life products, free of charge. Required treatment methods and recycling

¹ Throughout this thesis metric tons are used. 1 metric ton = 1.12 U.S. ton.

² Commission Proposal COM (2000) 347 final. p. 4.

³ European Environmental Bureau (EEB). (2001). *Towards Waste-Free Electrical and Electronic Equipment: EEB argumentation paper concerning the proposal for Directives on Waste Electrical and Electronic Equipment and on the Restriction of the use of certain Hazardous Substances in Electrical and Electronic Equipment*. Brussels: EEB. p. 3.

⁴ Commission Proposal COM (2000) 347 final. p. 4.

⁵ Commission Proposal COM (2000) 347 final. p. 4.

⁶ Basel Action Network (BAN) & the Silicon Valley Toxics Coalition. (2002). *Exporting Harm – The High-Tech Trashing of Asia*. pp. 1-2.

quotas are also outlined in this directive.⁷ The second directive, the RoHS, restricts the use of certain hazardous materials in EEE. Specifically, the proposed directive states that Member States shall ensure that the use of lead, mercury, cadmium, chromium and two flame retardants (polybrominated diphenyl ethers (PBDEs) and polybrominated biphenyls (PBBs)) is banned by 2006.⁸ The most controversial issue related to the RoHS has, at least in respect to heavy metals, been the decision to ban lead in solders used for printed circuit boards (PCBs).

On the whole, when it comes to the global consumption of lead, the usage of lead in batteries is currently not banned and at the same time the RoHS directive has made exception for the use of lead in cathode ray tubes (CRT). Opponents of the directive have, therefore, in consideration that the directive excludes the biggest usages of lead, questioned the validity of the decision to phase out lead in solder. Additionally, substituting lead in solder may not only require changes of the solder manufacturing and application processes. Due to increased processing temperature, substituting lead will also require that both the components and the PCBs, to which the components are soldered, can withstand the new conditions. Increased processing temperatures will also lead to increased energy consumption, which in turn could have a negative impact on the environment. Concerns about a too short phasing out period, set by the RoHS, and possible environmental impacts of the new lead-free solder alternatives have also been raised by the electronic industry.

The worldwide pressure to move away from lead-containing solders has given rise to different approaches around the world. In Europe the interest in using lead-free alternatives has been fuelled by the proposed RoHS directive. In Japan, the electronics industry was fast to note the implications of the proposed EU legislation and made lead-free solders into a virtue out of the anticipated necessity. Japanese companies also saw lead-free solders as a market benefit and as a result, Japan is today in front of Europe and America in developing lead-free soldering technologies. In the U.S. the debate about the financial and environmental impacts of moving to lead-free solders is still very active.⁹

1.2 Purpose

In light of the questions that still remain concerning the environmental benefits of substituting lead in solders, this thesis looks at the waste management of EEE and tries to assess possible impacts that the substitution of lead in solders might impose on recycling of PCBs. Furthermore, this study seeks to contribute to the understanding of the science behind the EU decision to ban lead in solders.

In order to achieve this, the thesis addresses the following questions:

1. What is the history behind the proposed EU directive on the Restriction of the use of certain hazardous substances in Electrical and Electronic Equipment?
2. What are the arguments behind the decision to substitute lead in electronic solders?
3. What is the current fate of the electronic solders at the end-of-life stage and how much solder is destined for the recycling system in operation today?
4. What activities to recycle electronic solders are taking place today?

⁷ van Rossem, C. (2001). *Environmental Product Information Flow: Communication of environmental data to facilitate product improvements in the ICT sector*. Lund: IIIEE Master Theses 2001:28. p. 22.

⁸ Commission Opinion COM (2002) 354 final.

⁹ Richards, B. (2001a). *Lead-free soldering – world's apart?* National Physical Laboratory. <http://www.npl.co.uk/npl/ei/news/eparticle.html> [2002, 30 July].

5. What is the current state of the art of waste management of electrical and electronic equipment? What is the fate of the solder contained in the PCBs?
6. What possible human health, environmental, economic, and technical impacts might the substitution of lead, with other heavy metals i.e., copper, silver, bismuth and tin, in solders have on the recycling of PCBs?

1.3 Scope and Limitations

The focus of this study is on electronic solder used in the electronics industry to predominantly attach components to printed circuit boards. During the last decades, tin-lead solders (Sn/Pb) have been the standard solders used because of their unique combination of material properties and low cost. However, in recent years, human health and environmental concerns have been raised regarding the use of lead in electronic solders and a movement away from lead-bearing solders is advancing.

The electronic solders studied in this thesis are eutectic¹⁰ tin-lead solder and four lead free alternatives, tin-copper (Sn/Cu), tin-silver-copper (Sn/Ag/Cu), and two types of tin-silver-bismuth (Sn/Ag/Bi and Sn/Ag/Cu/Bi), as displayed in Table 1-1.

The four lead-free alternatives investigated in this thesis are the same as the ones looked upon in the Lead-free Solder Project (LFSP) (for more information on the LFSP project, see Section 1.4.1). The decision to study these alternatives was based upon discussions with the industry partners of the LFSP. In light of the fact that the project had to scope down to a few alternatives, LFSP partners decided that these, based upon promising performance, were the most attractive ones.¹¹

Table 1-1. Selected solders looked upon in this thesis.

Solder Alloys	Composition (%)
Tin/Lead (Sn/Pb)	63 Sn/37 Pb
Tin/Copper (Sn/Cu)	99.3 Sn/0.7 Cu
Tin/Silver/Copper (Sn/Ag/Cu)	95.5 Sn/4.0 Ag/0.5 Cu
Tin/Silver/Bismuth (Sn/Ag/Bi)	42 Sn/1.0 Ag/57 Bi
Tin/Silver/Copper/Bismuth (Sn/Ag/Cu/Bi)	92.3 Sn/3.4 Ag/1.0 Cu/3.3 Bi

1.4 Methodology

In order to fulfil the objective of this thesis, various research steps were utilised. A number of different information sources have been explored. In the following section, the main research steps are described.

¹⁰ The lowest temperature at which a composition of two or more metals will melt. "Often the temperature is an anomaly, that is, it is much lower than the melting temperatures of only slightly different mixtures. Lead-tin solder is an example. Lead melts at 327°C, tin at 231°C. The lowest melting combination is 63 tin, 37 lead (180°C). Non-eutectic mixtures have a melting or softening range. Such mixtures do not flow well until thoroughly heated past the softening range. This softening phenomenon is what makes glazes hang onto the ware" (<http://digitalfire.com/ceramicmaterials/glossary.php>).

¹¹ Socolof, Maria. (2002, July 22). Sr. Research Associate, Center for Clean Products and Clean Technologies, University of Tennessee. Personal interview.

Initially, a literature review was performed to learn more about this specific research area. As part of this literature study, the EU directives on Waste from Electrical and Electronic Equipment (WEEE) and on the Restriction of the use of certain hazardous substances in Electrical and Electronic Equipment (RoHS) were studied. To identify characteristics of electronic solders and their applications, literature sources were used. Toxicological and eco-toxicological information about lead and the alternative metals were predominantly collected from TOXNET, which is a database on toxicology and hazardous chemicals published by the U.S. National Library of Medicine.

In order to identify current management of wastes of EEE and the fate of solders contained in PCBs, interviews with involved actors within the recycling industry were performed. Early in the thesis work, it was concluded that separate activities for recycling post-consumer solders used in electronics are currently not taking place on a large scale. On the other hand, solder collected as waste and leftover materials in the manufacturing and application stages of electronic solders is currently being recycled. This type of pre-consumer solder recycling is outside the main scope of this thesis and is not covered, in any detail, in this thesis. Instead, the focus on recycling activities is concentrated on the management of post-consumer waste EEE in general and where possible, on waste PCBs since they contain the solder. Study visits to a dismantling facility and to a copper smelter in Sweden were conducted to obtain onsite interviews with involved actors and to see how the management of waste EEE is conducted.

For further analyses the science and the argumentation behind the EU directives, interviews with actors involved in the decision making process on the EU level, were conducted.

This study, which addresses the post-consumer solder recycling, was part of a larger lifecycle project, the Lead-Free Solder Project (see Section 1.4.1), which addresses the total lifecycle environmental impacts of the selected lead-free solders. Thus, close contact with the Center for Clean Product and Clean Technologies at the University of Tennessee in Knoxville, which is a partner of LFSP, was maintained. Part of the thesis research, approximately four weeks, was performed in Knoxville, to be able to work in close connection with the group. This time provided extensive opportunities for discussions concerning and investigation of the current management of waste EEE in the United States. An increased understanding of the concerns about EU's decision to substitute lead in solders raised by the electronics industry, predominantly among U.S. companies, was also achieved. In an effort to try to assess the current waste management within this area, contacts with 50 of the Environmental Departments at the U.S state levels was made, of which answers were received from 20. However, on average these replies yielded little information.

1.4.1 The Lead-Free Solder Project

As previously described, this thesis was done in collaboration with the University of Tennessee Center for Clean Products and Clean Technologies, under the Lead-Free Solder Project (LFSP). The LFSP is a voluntary, cooperative project between the U.S. Environmental Protection Agency Design for the Environment (DfE) Program, the University of Tennessee, the electronic trade associations EIA (Electronic Industries Alliance) and IPC (Association Connecting Electronics Industries) and individual industry companies. The project was initiated in the spring of 2002 with the purpose of assessing the life-cycle impacts of lead and lead-free solders. Due to concerns that research until now has focused on performance and not on the possible environmental risks of substituting lead in solders, the focus of the project is predominantly on assessing the life-cycle environmental impacts. The project is expected to evolve into a final project report in June 2003. For more information about LFSP, see its homepage on:

<http://eerc.ra.utk.edu/ccpct/lfsp-projectinfo.html>

1.5 Structure of the Thesis

Chapter 2 provides an introduction to lead and solders. The chapter gives a short description of why lead has been so extensively used in solder. It also outlines performance requirements that new lead-free solders have to fulfil to replace the currently used tin-lead solders.

Chapter 3 gives a background to the activities to phase out lead in solder. In this context, earlier activities to phase out lead in other applications and the reasoning behind those decisions are presented. To understand the science or argumentation behind the RoHS directive, Chapter 3 presents the history behind the directive and the associated WEEE directive. The chapter assesses the actors and stakeholders who actively took part in the decision to phase out lead in solder and the argumentations pro and con the proposal that were used during the development of the RoHS directive.

Chapter 4 assesses the current activities to recycle solders in electrical and electronic equipment. The chapter gives a description of the recycling activities of waste EEE, with a focus on PCBs that contain the solders, which take place today. Furthermore, an assessment of the fate of the tin-lead solder and the lead-free alternatives, addressed in this thesis, in the recycling systems is conducted.

Chapter 5 evaluates possible impacts that the substitution of lead in solders might have on the recycling of waste EEE and PCBs. The eutectic tin-lead solder is compared with the lead-free solder alternatives and possible impacts of a substitution, from an environmental, technical and economic perspective, are assessed.

Finally, the conclusions and recommendations of the thesis are presented in Chapter 6.

2. Introduction to Lead and Solders

2.1 Lead Production and Use

Lead is a soft, heavy metal with a low melting point (327.5 °C) and a low boiling point (1740°C), which make it one of the easiest metals to cast and also one of the most volatile metals. Some experts believe that it was used as early as 5000 B.C in Egypt for pottery glazes. Around 2000 B.C., lead was also used in coins in China. The best-known use of lead, in ancient times, is probably the use of lead in piping in Roman water systems.^{12, 13} It is believed that, for a brief period, the Roman Empire produced as much as 100 000 tons¹⁴ of lead annually. The Roman usage of lead, not only for water pipes but also for wine receptacles, most likely resulted in severe impacts on the health of the Romans.¹⁵ Some historians even argue that lead poisoning might have caused the fall of the Roman Empire.¹⁶

At the beginning of the 20th century, the annual worldwide lead production amounted to 1 million tons. During the period 1970 to 2000, the global lead production increased from 4.5 million tons to 6.5 million tons.¹⁷ In reality, the global mine production of lead had its peak in 1977 with 3.65 million tons and has since decreased somewhat. However, during the last decades, the production of secondary (recycled) lead has increased significantly, which explains the increase of the total yearly lead production. In fact in 1998, secondary lead accounted for 60% of the annual lead production in the western world, compared to 43% in 1980 and 33% in 1965.¹⁸

The modern uses of lead are very dispersed. As displayed in Table 2-1, the major uses of lead today are for storage batteries (80.8%), paint, glass and ceramic products, pigments and chemicals (4.8%), ammunition (4.7%), and sheet lead, cable covering, casting metals, brass and bronze (5.0%).^{19, 20} Lead used in electronic solders only accounts for about 0.5% of the total usage (see Figure 2-1).

¹² OECD. (1993). *Risk Reduction Monograph No. 1: Lead – Background and national experience with reducing risk*. Paris. p.46.

¹³ Ayres, R., Ayres, L. & Råde, I. (2002). *The Life Cycle of Copper, its Co-Products and By-Products*. Report for the Mining, Minerals and Sustainable Development (MMSD) project of the International Institute for Environment and Development (IIED). p.7.

¹⁴ Throughout the thesis, metric tons are used.

¹⁵ Ayres, R., Ayres, L. & Råde, I. (2002). *The Life Cycle of Copper, its Co-Products and By-Products*. p.7.

¹⁶ Lee, N-C. (2002). *Reflow Soldering Processes and Troubleshooting: SMT, BGA, CSP and Flip Chip Technologies*. Woburn: Butterworth-Heinemann. p. 251.

¹⁷ European Commission. (2002). *Heavy Metals in Waste, Final Report*. Project ENV.E.3/ETU/2000/0058. Denmark: COWI. p. 22.

¹⁸ Ayres, R., Ayres, L. & Råde, I. (2002). *The Life Cycle of Copper, its Co-Products and By-Products*. pp. 56-57.

¹⁹ Turbini, L., Munie, G., Bernier, D., Gamalski, J. & Bergman, D. (2001). Examining the Environmental Impact of Lead-Free Soldering Alternatives. *IEEE Transactions on electronic packaging manufacturing*, 24, 1.

²⁰ Tiefert, Karl. (2002). Roadblocks to Pb-free Electronics – A Components Manufacturer's Perspective. In: *Conference Proceedings from the IPC and JEDEC International Conference on Lead-Free: Electronic Components and Assemblies*, Doubletree Hotel San Jose, 1-2 May 2002. Northbrook: IPC. p. 218.

Table 2-1. Lead consumption divided into application areas.

Product	Consumption (%)
Storage batteries	80.8
Other oxides (paint, glass and ceramic products, pigments and chemicals)	4.8
Ammunition	4.7
Sheet lead	1.8
Cable covering	1.4
Castling metals	1.1
Brass and bronze, billets and ingots	0.7
Pipes, traps, other extruded products	0.7
Solder (non-electronic)	0.7
Electronic solder	0.5

Source: Tiefert 2002.

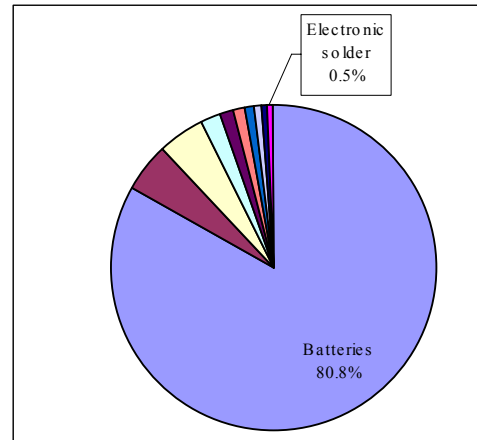

Figure 2-1. Percentage of lead used by the electronic solder industry.

2.2 Electronic Solder Use

For more than 50 years, lead-containing solders have been used throughout the electronics industry for attaching components to PCBs.²¹ These solders have been extensively used because they are inexpensive, perform reliably under a variety of operating conditions, and possess unique characteristics such as low melting point, high strength ductility and fatigue resistance, high thermal cycling and joint integrity.²²

Currently, the amount of solder produced annually for the electronics industry is estimated to range between 100 000 tons and 125 000 tons.²³ The most commonly used solder is the eutectic tin-lead alloy containing 63% tin and 37% lead (63 Sn/37 Pb).

2.3 Lifecycle of Solder

A simplified model of the lifecycle of solders is presented in Figure 2-2. The solder is first manufactured from primary and secondary raw materials.²⁴ In the next step, the application step, the solder is used to attach components to PCBs, which in turn are placed into EEE to produce finished products. The electrical and electronic products are then marketed and used by the purchaser. At end-of-life, the EEE are destined for recycling, incineration or deposition in landfills.

The focus of this thesis is on the fate of solder in current recycling activities at the end-of-life stage. Recycling of solders also takes place at an earlier stage of the lifecycle, i.e., in connection with the application and manufacturing steps. This type of recycling, which in Figure 2-2 is labelled as *solder recycling*, treats leftover solder and oxides of solder (dross) from the application and manufacturing steps to and recover secondary materials, which in turn can be fed back into the production chain. These process techniques to recycle solder differ from those for recycling waste EEE at the end-of-life and are not addressed in this thesis.

²¹ Richards, B. (2001a). *Lead-free soldering – world's apart?* National Physical Laboratory..

²² Richards, B. (2001b). *The Reality of Lead-free Soldering*. <http://www.npl.co.uk/npl/ei/documents/matworld.pdf> [2002, 6 August].

²³ Deubzer, O., Griese, H. & Suga, T. (2001). Lead-free Soldering – Future Aspects of Toxicity, Energy and Resource Consumption. *Proceedings EcoDesign 2001: Second International Symposium*. pp. 952-957.

²⁴ The difference between primary and secondary raw material is that the latter consists of recycled material.

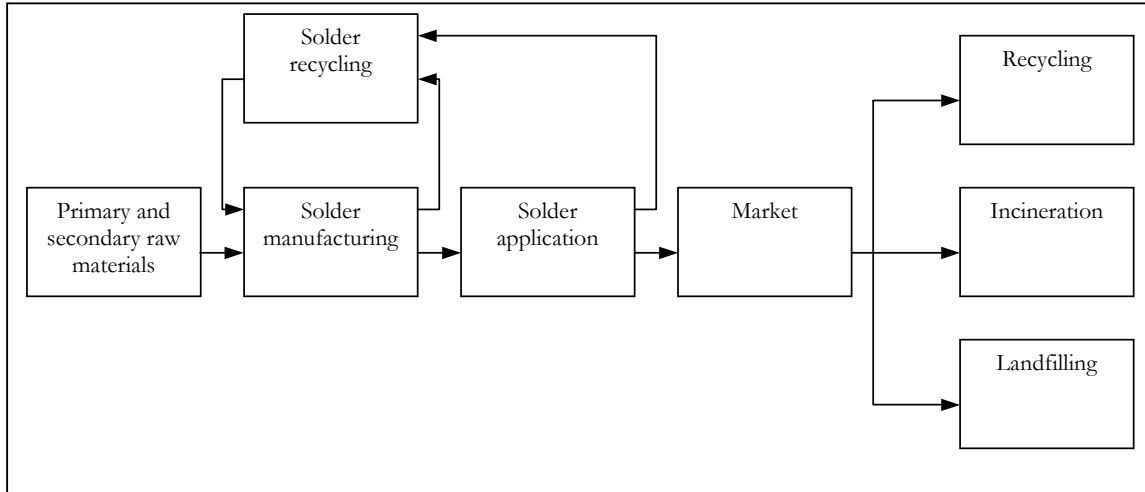

Figure 2-2. The lifecycle of electronic solder, displaying the various steps involved, from production of solder from raw materials through the end-of-life treatment of EEE containing the solders. Solder application refers to the process when solder is applied to connect components to PCBs. The PCBs are thereafter fitted into products to produce EEE that are released on the market. Solder recycling, compared to end-of-life recycling, refers to the recycling of leftover solder and oxidised solder from the manufacturing and application steps.

2.4 Application

Solder is used to attach components to PCBs. The components are most commonly attached by surface mount technology (SMT) or through-hole technology (THT). In the conventional THT, component leads or terminators are inserted in holes in the PCB as compared to SMT where flat leaded or leadless components are mounted on the surface of the PCB (see Figure 2-3). By mounting components on the surface of PCBs, the SMT allows for a higher degree of automation, higher component density, and smaller volume.²⁵ Since no leads protrude through the various layers of a board, SMT also enables components to be mounted on both sides of the board without regards for what components are placed on the opposite side. Today's small sized cellular phones and laptops would not be possible without the use of SMT.²⁶ However, THT is still used in most products that do not need to be miniaturized e.g., TVs, videos, and home audio equipment.

In the process where the PCB is populated with components, two major solder application processes are used, i.e., wave soldering and reflow soldering. Through-hole components require wave soldering, while surface mount components can be attached by either application process.

²⁵ Lee, N-C. (2002). *Reflow Soldering Processes and Troubleshooting: SMT, BGA, CSP and Flip Chip Technologies*. p. 1.

²⁶ Blackwell, G. (1999). *Integrated Design Using SMT*.

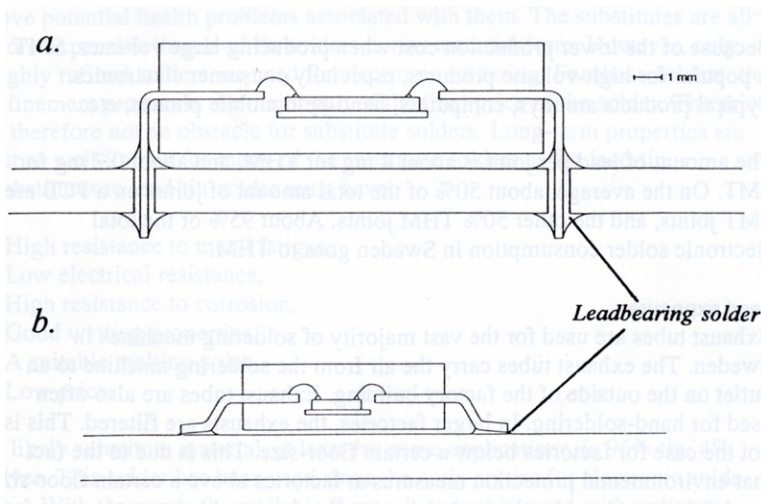

Figure 2-3. The two most common methods for soldering components to PCBs, a) Through-Hole Technology (THT) and b) Surface Mount Technology (SMT). Source: Swedish National Chemical Inspection 1994b.

2.4.1 Wave Soldering

Wave soldering was developed in England in 1956 and has since then been the most important soldering process. As can be seen in Figure 2-4, the wave soldering process, in principle, consists of three steps i.e. application of flux, pre-heating and the true wave-soldering step. In the first step, the PCB is transported through a flux application station where flux is applied. The purpose of the flux is predominantly to improve the wettability of the solder to the connection pad and to remove any oxide layers between the solder and the metals on the board, to ensure optimal surface contact. In the next step, the board is transported to a pre-heat section where the flux is activated and solvents used to dilute the flux are dried. This process step also serves to reduce the thermal stress placed on the PCB in the last wave-soldering step. In the final step, the bottom of the board passes over a molten wave of solder and solder joints are subsequently formed.^{27, 28}

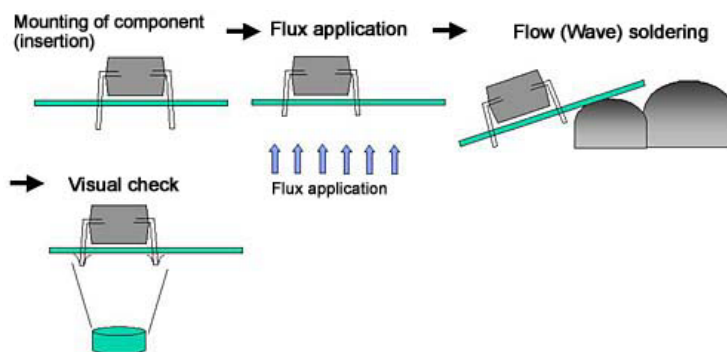

Figure 2-4. Process description of wave soldering with through-hole components. After the leads of the components are inserted to the holes on the board and flux has been applied, a molten wave of solder is applied to form solder joints. Source: NEC Electron Devices 2002.

²⁷ Chong, L., Howell, K. & Apell, M. (2000). *Getting Started in Wavesoldering*. *Electronics Engineer* February 2000 http://www.cetasia.com/ART_8800030101.HTM [2002, 28 August].

²⁸ Blackwell, Glenn R. (1999). Integrated Design Using SMT. In: *29th ASEE/IEEE Frontiers in Education Conference*, 3. 13d/12-13d/16.

2.4.2 Reflow Soldering

Reflow soldering was introduced to improve the SMT. In this process, a solder paste, containing small solder spheres, flux and solvents, are first applied to the board where the surface mount components are subsequently placed.²⁹ The solder paste serves as a temporary glue that holds the components in place prior to the soldering process. The populated PCB is then heated to above the melting point of the solder to reflow the solder paste. At this temperature, the flux is activated, oxides are removed and the solder subsequently forms solder joints.³⁰ For a schematic picture of the process see Figure 2-5.

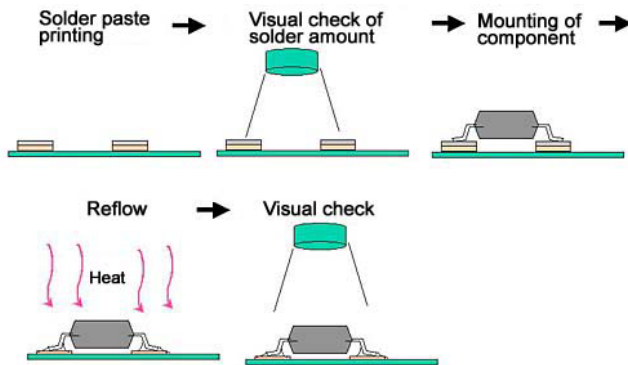

Figure 2-5. Process description of reflow soldering with surface-mount components. Solder paste is applied to the areas of the board where components are subsequently to be placed. Heat is thereafter applied to the populated board to melt the solder paste and thus form solder joints. Source: NEC Electron Devices 2002.

2.5 Performance Requirements

Any lead-free replacement needs to match or come close to matching lead solders' reliability and manufacturability. The thermal fatigue of the solder is critical to the reliability of electronic circuits, as these, during usage, are switched on and off, which means that they undergo heating and cooling cycles that constantly expand and contract the PCB materials and solder joints. This stresses the solder joints and may ultimately cause failure of the circuits. Another important characteristic of solder is the wettability, also known as solderability, which describes the efficiency and speed with which the solder spreads over a metal surface. This is a factor which determines the ease of soldering and hence the manufacturing of the PCBs.³¹

The cost and availability of replacement metals also play an important part in considering alternatives to tin-lead solder. Concern about limited availability and high costs of bismuth and silver have been documented.³² However, most concern has been expressed about the higher processing temperatures required for lead-free solders. In wave soldering the temperatures must be approximately 10°C higher and in reflow soldering the temperatures must be about 20 to 25°C higher. This can have an impact, on

²⁹ The Swedish National Chemicals Inspectorate. (1994b). *Some Uses of Lead and Their Possible Substitutes – the use of lead in electronics, building, materials, weights, metal working, professional fishing, and miscellaneous other applications*. Stockholm: KEMI p. 18.

³⁰ Lee, N-C. (2002). *Reflow Soldering Processes and Troubleshooting: SMT, BGA, CSP and Flip Chip Technologies*.p. 6.

³¹ Trumble, B. (1998). Get the Lead Out! New solders rely on lead-free alloys of tin and do away with the toxic component. *IEEE Spectrum*, 35, 5. pp. 55-60.

³² Trumble, Bill. (1998). Get the Lead Out! New solders rely on lead-free alloys of tin and do away with the toxic component. pp. 55-60.

the energy consumption during the application process and on the reliability of the components and PCBs.³³ In Box 2-1, different criteria are used for screening candidate lead-free solders are summarised.

Box 2-1. Criteria that must be fulfilled by lead-free solder alternatives.

- | |
|---|
| <ul style="list-style-type: none"> -Non-toxic -Available and affordable -Narrow plastic range -Acceptable wetting -Material manufacturability -Acceptable processing temperature -Form reliable joints |
|---|

Source: Lee 2002.

2.6 Lead-Free Solders

There are numerous lead-free solders available today that are considered to be viable candidates for replacing the eutectic tin-lead solder. In this study the same lead-free alternatives were selected as in the LFSP project (see Sections 1.3 and 1.4.1 for more information about the LFSP project). In the following section, short descriptions of the lead-free alternative solders, studied in this thesis, are given.

Tin-copper (99.3 Sn/0.7Cu)

The tin-copper alloy is currently used by a part of the electronics industry as a low cost alternative to tin-lead solder in wave soldering applications. The alloy seems to work well in high temperature applications, e.g. required by the automotive industry. The tin-copper solder has a melting point of 227°C, which is the highest of the solders addressed in this study.³⁴

Tin-silver-copper (95.5 Sn/4.0 Ag/0.5Cu)

Based upon the results of several electronic-organisation's studies, the tin-silver-copper has been found to be the top candidate for replacing tin-lead. The tin-silver-copper is ideal for operating temperatures up to 175°C. The solder has a melting point of between 217-219°C and can be used in both wave and reflow applications.

Tin-silver-bismuth (42 Sn/1.0 Ag/57 Bi) and tin-silver-copper-bismuth (92.3 Sn/3.4 Ag/1.0 Cu/3.3 Bi)

Bismuth is added to reduce the melting point of the lead-free alloys. Thus, the lower melting points of tin-silver-bismuth and tin-silver-copper-bismuth (208-213°) make them suitable for use with heat sensitive components. The two bismuth-containing solders are seen as viable alternative for reflow applications in some segments of the electronics industry.

³³ Cookson Electronics. (2002). *Soldering Temperatures*. http://www.alphametals.com/lead_free/ [2002, 5 September].

³⁴ Promosol. (2002). *Lead-Free*. <http://www.desab-elektronik.se/prod/promosol/Leadfree11-compresse.pdf> [2002, 20 August].

2.7 Toxicological and Ecological Aspects of Tin-Lead and of Lead-Free Solders

The following section is a short description of the toxicological aspects and the environmental fate of the metals contained in the tin-lead and the lead-free solders.

2.7.1 Lead

Despite long-term acceptance of lead by human society, lead poisoning is now well recognized as a health threat. According to the EU directive 67/548/EEG, lead and lead compounds are classified as reproduction-toxic, dangerous when inhaled and ingested and very toxic to aquatic biota. Lead compounds are also known to cause long-term hazardous effects on the aquatic environment.³⁵ The U.S. EPA has classified lead as a persistent bioaccumulative toxic (PBT) chemical – a pollutant that is highly toxic, long lasting and thereby, can build up in the food chain to levels that are harmful to humans and the environment.³⁶ Quite contradictory to the U.S. EPA's claims, the European Commission has stated, in its report on *Heavy Metals in Waste* report published in February 2002, that in general, lead does “not bioaccumulate and there is no increase in concentration of the metal in food chains”.³⁷

In general, the major exposure pathway for non-smoking adults is through food and water. Airborne lead may contribute significantly to occupational exposure and exposure of smokers, the latter through smoking. For infants and young children, lead in dust and soil have been identified as major exposure pathways. These last exposure pathways, to infants and young children, are of particular concern as children have a tendency to absorb lead more readily than adults. In adults, approximately 10% of the dietary lead is absorbed while the figure for infants and young children can be as high as 50%.³⁸

Once in the body, lead is distributed into the blood stream, the soft tissues and the bones. In the bones, lead is known to accumulate and later on, many years after the lead exposure has stopped, the bone tissue can serve as an endogenous source of lead that may release lead back into the blood.

The toxicological effect of major concern to humans is the damage that lead can cause to the central nervous system. Epidemiological studies indicate that low level exposure to fetus may lead to “reprotoxic effects, i.e. damage to the learning capacity and the neuropsychological development”.³⁹ A correlation between higher lead content in the blood and a lower IQ has also been shown in studies of children. Low lead blood levels have been shown to cause slowing of the nerve conduction velocity. “Impairment of psychological and neurobehavioral functions has also been found after long-term lead exposure of workers. [Furthermore,] lead has been shown to have effects on haemoglobin synthesis and anemia has been observed in children at lead blood levels above 40 µg/d”.⁴⁰ Adults exposed to lead might also suffer from high blood pressure.⁴¹

³⁵ Gabrielsson, Göran. (2002, July 12). The Swedish National Chemicals Inspectorate. *Re: Bly i lötlenn* [Lead in solder]. E-mail to Ulrika Kindsjö.

³⁶ U.S. Environmental Protection Agency. (2001b). *EPA Announces New Toxic Release Inventory Reporting Requirements for Lead and Lead Compounds*. http://www.epa.gov/tri/lawsandregs/lead/pb_fact_sheet.pdf [2002, 13 August].

³⁷ European Commission. (2002). *Heavy Metals in Waste, Final Report*. p. 9.

³⁸ European Commission. (2002). *Heavy Metals in Waste, Final Report*. p. 9.

³⁹ European Commission. (2002). *Heavy Metals in Waste, Final Report*. p. 10.

⁴⁰ European Commission. (2002). *Heavy Metals in Waste, Final Report*. p. 10.

⁴¹ Le Fèvre, P. (2002). Environmental Issues in Power Electronics (Lead Free). In: *Applied Power Electronics Conference and Exposition. APEC 2002. Seventeenth Annual IEEE, 2002, 1*. pp. 121-125.

In the environment, inorganic lead will mainly be particulate bound with relatively low mobility and bioavailability. Under most circumstances, humic substances will immobilize the lead. However, as the alkalinity and pH decreases the mobility of lead increases.

Lead is classified as very toxic for the aquatic environment and the acute toxicity of lead to aquatic organisms (LC_{50})⁴² is measured to be within 1.5-40 mg/l, while the chronic toxicity (NOEC)⁴³ of lead is less than 0.3 mg/l.⁴⁴ The bioconcentration or bioconcentration factor (BCF)⁴⁵ of lead in fish is low to moderate in most species; for two fresh water fish species the BCF has been estimated to 42 respectively 45. However, BCF's for lead for certain other species, such as blue mussels are much higher (range of 499 to 1 700).⁴⁶

2.7.2 Tin

In general, organic tin compounds are relatively harmless to humans as little of the amounts ingested or inhaled are absorbed in the body. However, in large amounts, tin compounds can cause stomach aches, anemia, liver and kidney problems, and skin and eye irritation. Long-term inhalation of inorganic tin, up to 15-20 years, may cause a benign pneumoconiosis, known as stannosis or so-called tin-lungs in humans.^{47, 48}

Tin is toxic for many aquatic species. The mobility of tin is very low but increases with increasing acidity. The acute toxicity of tin to aquatic organisms (LC_{50}) is 0.29-50 mg/l and the chronic toxicity (NOEC) (tin (+4)) is 0.09-7.8 mg/l. Tin is evaluated to be very toxic for the aquatic environment.⁴⁹

2.7.3 Copper

The human toxicity of copper is relatively low.⁵⁰ However, copper and copper compounds can cause respiratory irritation, abdominal pain, nausea, vomiting, and diarrhea as documented when factory workers are exposed to copper dust.⁵¹

Ecotoxicological effects of copper have been observed in laboratory studies⁵² however, no complete data that would support this have been found during this study.

⁴² LC_{50} = Lethal concentration, which causes the death of 50% of a group of test animals.

⁴³ NOEC = No observed effect concentration.

⁴⁴ Christensen, F., Jørgensen, T. & Nielsen, I. (2000). *Environmental and technical characteristics of conductive adhesives versus soldering*. Working Report No 16. Miljøstyrelsen [The Danish Environmental Protection Agency]. pp. 12-13.

⁴⁵ BCF describes the ratio between the concentration of a chemical in an organism living in an aquatic environment and the concentration in the surrounding water.

⁴⁶ Socolof, M., Overly, J., Kincaid, L. & Geibig, J. (2001). *Desktop Computer Displays – A Life-cycle Assessment*. Vol. 1. Design for the Environment Computer Display Project. U.S. EPA. p. 4.16.

⁴⁷ Agency for Toxic Substances and Disease Register (ATSDR). (1992). *Toxicological Profile for Tin and Tin Compounds*. U.S. Public Health Service. p. 1.125.

⁴⁸ Christensen, F., Jørgensen, T. & Nielsen, I. (2000). *Environmental and technical characteristics of conductive adhesives versus soldering*. p. 11.

⁴⁹ Christensen, F., Jørgensen, T. & Nielsen, I. (2000). *Environmental and technical characteristics of conductive adhesives versus soldering*. p. 11.

⁵⁰ TOXNET. (2002b). *Copper, Elemental - CASRN: 7440-50-8*. <http://toxnet.nlm.nih.gov/cgi-bin/sis/search/F./temp/~BAA2fa40N:1> [2002, 28 August].

⁵¹ Agency for Toxic Substances and Disease Register (ATSDR). (1990). *Toxicological Profile for Copper*. U.S. Public Health Service. pp. 2.12-2.17.

2.7.4 Silver

Silver is highly inert and is generally considered to be of low human toxicity. Silver accumulates in the body and long-term exposure may cause argyria, which is a silver poisoning that leads to a permanent blue-grey discoloration of the skin, eyes and mucous membranes.^{53, 54} Reported silver concentrations in the skin of persons with argyria are somewhere between 50-70 mg/kg dry wt, which is several thousand times higher than normal values.⁵⁵ Although deposition of silver is permanent, argyria is believed to be medically benign and is not associated with any adverse health effects.⁵⁶ No evidence that silver is carcinogenic to humans has been reported.⁵⁷

Silver is evaluated to be toxic for the aquatic environment.⁵⁸ Some marine and estuarine life forms, predominantly invertebrates and algae, have, in laboratory studies, been found to be sensitive to very low concentrations of silver (<1 to 14 µg/l).⁵⁹ Nevertheless, widespread concentrations of dissolved silver in such concentrations are rarely found, even in polluted waters. From the information collected during the study, there seems to be eco-toxicological uncertainties of the effects of silver in the environment and more careful studies are needed before any conclusion can be drawn.

2.7.5 Bismuth

High-level exposure to bismuth can “cause renal failure with degeneration and necrosis of the epithelium of the renal proximal tubules, fatty changes and necrosis of the liver, reversible dysfunction of the nervous system, skin eruptions and pigmentation of the gums and intestine”.⁶⁰ Some studies have shown that bismuth and bismuth compounds might be carcinogenic or co-carcinogenic in rats. Also, some studies have shown that bismuth can cause chromosomal aberrations in rats. However, more studies are required to develop a more complete picture of the toxicity of bismuth.⁶¹

In general, relatively little information seems to be known about the effects of bismuth. Some argue that bismuth is “the new ecologically green metal”, considering that it is non-toxic or at least the least

⁵² Smith, Edwin B. (2002). Environmental Impacts and Toxicity of Lead Free Solders – Including Japanese and European Union Regulations. KTEC Electronics. In: *Conference Proceedings from the IPC and JEDEC International Conference on Lead-Free: Electronic Components and Assemblies*, Doubletree Hotel San Jose, 1-2 May 2002. Northbrook: IPC.

⁵³ Christensen, F., Jørgensen, T. & Nielsen, I. (2000). *Environmental and technical characteristics of conductive adhesives versus soldering*. pp. 12-13.

⁵⁴ Smith, Edwin B. (2002). Environmental Impacts and Toxicity of Lead Free Solders – Including Japanese and European Union Regulations. KTEC Electronics. In: *Conference Proceedings from the IPC and JEDEC International Conference on Lead-Free: Electronic Components and Assemblies*, Doubletree Hotel San Jose, 1-2 May 2002. Northbrook: IPC.

⁵⁵ TOXNET. (2002). *Silver* - CASRN: 7440-22-4. <http://toxnet.nlm.nih.gov/cgi-bin/sis/search/P./temp/~AAAZUaWHO;2> [2002, 28 August].

⁵⁶ U.S. Environmental Protection Agency. (1991). *Silver. Integrated Risk Information System*. <http://www.epa.gov/iriswebp/iris/subst/0099.htm> [2002, 28 August].

⁵⁷ U.S. EPA. (1991). *Silver. Integrated Risk Information System*.

⁵⁸ Christensen, F., Jørgensen, T. & Nielsen, I. (2000). *Environmental and technical characteristics of conductive adhesives versus soldering*. p. 12.

⁵⁹ Luoma, S., Ho, Y. & Bryan, G. (1995). Fate, Bioavailability and Toxicity of Silver in Estuarine Environments. *Marine Pollution Bulletin*, 31, 1-3. pp. 44-54.

⁶⁰ TOXNET. (2002). *Bismuth Compounds* - CASRN: No CAS RN. <http://toxnet.nlm.nih.gov/cgi-bin/sis/search/P./temp/~AAAAn0aGpy;1> [2002, 28 August].

⁶¹ Smith, Edwin B. (2002). Environmental Impacts and Toxicity of Lead Free Solders – Including Japanese and European Union Regulations. KTEC Electronics. In: *Conference Proceedings from the IPC and JEDEC International Conference on Lead-Free: Electronic Components and Assemblies*, Doubletree Hotel San Jose, 1-2 May 2002. Northbrook: IPC.

toxic metal of all, as known today.⁶² Others are more careful and say that bismuth might in the near future be listed as a hazardous element and thus should be avoided.⁶³

⁶² Rohr, O. (2002). Bismuth – the new ecologically green metal for modern lubricating engineering. *Industrial Lubrication and Tribology*, 54, 4. pp. 153-164.

⁶³ Fuchs, Stefan-Georg. (2002, July 5). Umicore Precious Metals. *Re: Tin/lead solders vs. Alternatives*. E-mail to Ulrika Kindsjö.

3. Phasing Out Lead in Solder

3.1 History of Phasing Out Lead

Usage of lead involves dispersion throughout all sections of the environment. The route of exposure of lead to humans and the environment can be divided into the following ways:⁶⁴

- Exposure of humans and the environment during mining, refining, and production processes,
- Direct exposure of humans through usage,
- Direct exposure of the environment through usage, and
- Indirect exposure of the environment, and in turn of humans via the environment, by waste treatment and disposal activities.

The drive to reduce lead is not new. Instead there has been a continuous worldwide environmental movement away from the use of lead in products. Historically, the focus on reduction or phase out of lead has been on lead used in products that may cause direct exposure of humans and/or the environment. Lead in domestic water pipes, petrol, paint, fishing weights, ammunition, wine bottle capsules, plumbing solders etc has been the centre of environmental pressure.

Petrol

Organic lead compounds, particularly tetraethyl lead and tetramethyl lead, have been added to petrol since 1923 to increase the octane and thereby enhance performance. The big concern about leaded petrol comes from the fact that when the petrol is burned lead particles will unavoidably and efficiently disperse into the human environment. Extremely small particles of lead are emitted to the atmosphere, where they can persist for weeks before settling. It has been estimated that only about 10% of the lead from emissions from vehicles settles within 100 m of the roadway. Another 45% settles within the range of 20 to 200 km. The remaining, 35% is airborne and is carried on long-range atmospheric transportation. Besides contaminating the environment as fallout, lead particles may also pose big health risks, as they can easily be absorbed through inhalation. When in the lungs, the small particles are absorbed into the blood with almost 100% efficiency.⁶⁵

In the early 1970's, in response to growing concerns about the health effects of lead, governmental movements started to take place to reduce the use of lead additives in petrol. At that time in the U.S., auto manufacturers were required to place catalytic converters in new cars sold. Because leaded petrol destroys the functionality of converters, the U.S. Environmental Protection Agency (U.S. EPA) required that lead-free petrol should be available from the beginning of 1973. In parallel to the introduction of lead-free petrol, governments were also beginning to reduce the amount of lead allowed in leaded petrol.⁶⁶ Today, lead additives in petrol has been extensively restricted or phase-out in most Western countries.

⁶⁴ Ponsaing, P. & Hansen, E. (1995). *Some Issues Related to the Development of a Possible OECD Council Act on Lead*. TemaNord 1995:564. Copenhagen: Nordic Council of Ministers. p. 6.

⁶⁵ Alliance To End Childhood Lead Poisoning (AECLP) & Environmental Defense Fund. (1994). *The Global Dimensions of Lead Poisoning*. http://globalleadnet.org/pdf/Toxicity_of_Lead.pdf [2002, 30 July].

⁶⁶ Alliance To End Childhood Lead Poisoning (AECLP) & Environmental Defense Fund. (1994). *The Global Dimensions of Lead Poisoning*.

Paints

Because of the durability of lead, lead compounds have also been added to paints for hundreds of years. In the 18th and early 19th centuries, lead carbonate, or better known as white lead, was very popular as a base for oil based paints. White lead paints could often contain up to 50% lead by dry weight. By the turn of the last century, the toxicity of white lead was first recognized and in 1904, a study in Australia, identified lead paint as the source of childhood lead poisoning. However, after this lead paints were still sold for decades in many countries. In 1921, the International Labour Organization developed a treaty that banned interior use of paints, made from white lead and lead sulfate that contained more than 2% lead. In the following years the treaty was signed by most European countries and by many other countries. Unfortunately however the treaty was not very successful. Among other things it did not apply to exterior use of lead paints as well as it still allowed up to 2% of lead in pigments applied to interiors.

During the last decade, several OECD nations have restricted or banned the residential use of lead-based paints, due mainly to occupational exposure risks and risks associated with painting and grinding.⁶⁷ In 1976, EU banned usage of white lead and lead sulphates by passing the directive 76/769/EEC.⁶⁸ But the fact that a lot of old houses are painted with lead-based paints, makes the hazards from prior use remain an actual or potential threat for decades or even centuries. In the U.S. it has been declared that lead-based paints still actually remains the most significant source of moderate and severe lead poisoning in children.⁶⁹

Crystal Glass and Ceramic Glazes

For a long time, lead oxides have been used as a raw material in crystal glass and ceramic glazes to among other things promote brilliance. In semi-crystal approximately 5% lead oxide is used and in whole crystal about 24 to 30%. Concerns about uses of lead in crystal glasses have mostly concerned the occupational risks.⁷⁰ For the use of lead in ceramic glazes concerns have also been addressed to the leaching of lead when used. In 1992, the State of California Department of Health Services issued a health alert advising consumers not to cook food in Mexican bean pottery, after one such pot had been found to leach more than 5 000 ppm (parts per million).⁷¹ The phasing out of lead in crystal glass has indeed been delayed or hindered much due to the European directive 69/493 EEC from 1969 that states that a lead oxide content of between 24 and 30 % must be present in glass if it is to be classified as whole crystal.⁷²

Ammunition and Sinkers

Lead has also been used extensively in ammunition and fishing sinkers, which results lead has been and still is being deposited on fields and woodlands and in lakes, open water and marshes. During the past few decades, it has become apparent that lead has adverse effects upon wild birds and other organisms and actions to substitute lead have been started. Lead-induced waterfowl deaths have been recorded in

⁶⁷ Swedish National Chemicals Inspection. (1994a). *Phasing Out Lead and Mercury*. Stockholm: KEMI. p. 19.

⁶⁸ Swedish Committee on New Guidelines on Chemical Policy. (2000). *Varor utan faror – förslag till genomförande av nya riktlinjer inom kemikaliepolitiken* [Non-Hazardous Products – Proposals for Implementation of New Guidelines on Chemicals Policy]. SOU 2000:53. Annex 6. p. 506.

⁶⁹ Alliance To End Childhood Lead Poisoning (AECLP) & Environmental Defense Fund. (1994). *The Global Dimensions of Lead Poisoning*.

⁷⁰ Swedish National Chemicals Inspection. (1994a). *Phasing Out Lead and Mercury*. p. 15.

⁷¹ Alliance To End Childhood Lead Poisoning (AECLP) & Environmental Defense Fund. (1994). *The Global Dimensions of Lead Poisoning*.

⁷² Swedish National Chemicals Inspection. (1994a). *Phasing Out Lead and Mercury*. pp. 15-16.

some 15 countries. The U.S. banned lead shot on federal land in 1991. Since that time, lead shot has also been banned in Canada, Denmark, The Netherlands, Sweden, and Norway, and in areas of Australia, Finland and Belgium.^{73, 74, 75}

3.2 Activities to Phase Out Lead in Electronics

With respect to environmental protection, the U.S., Japan and Europe have developed different initiatives to reduce and limit the uses of hazardous chemicals in electronics. In the following section a short history of the activities to phase out lead in electronics is given.

3.2.1 U.S.

In early 1990, one attempt to ban lead from electronic solder was initiated in the U.S. Congress. On May 25, 1994 the Senate passed the bill, the Lead Exposure Reduction Act (S.729)⁷⁶, which restricts the use of lead as follows:⁷⁷

- “The manufacture, importation or processing of paint, toys and recreational game pieces, plumbing solder and fixtures, and ink that exceed certain levels of lead content deemed to be unsafe will be prohibited; these new standards will be phased in for various specified products;
- The Environmental Protection Agency (EPA) will inventory all lead-containing products used in commerce, make a list of those products in that inventory that it thinks may present an unreasonable risk of injury to human health or the environment, and require the labelling of products on that list according to their lead content; and
- All lead acid batteries will have to be recycled”.

From the beginning, the bill had included a ban of all lead containing alloys, including electronic solders. However, after intense lobbying by the U.S. electronics industry, electronic solders were removed from the bill.⁷⁸

In 1986, the Congress established the Toxic Release Inventory (TRI) Program under the Emergency Planning and Community Right-to-Know Act 1986. Four years later, the TRI was expanded by the Pollution Prevention Act. The purpose of TRI is to increase “the public’s knowledge of, and access to, information on the release and other waste management quantities of toxic chemicals in their communities”⁷⁹. Facilities that manufacture, process, or use chemicals in quantities that exceed established thresholds must file release reports for these compounds and methods to estimate releases

⁷³ Royal Forest and Bird Protection Society of New Zealand Inc. (2001). *Lead Shot and Sinkers – Poisoning New Zealand’s waterways*. http://globalleadnet.org/pdf/Toxicity_of_Lead.pdf [2002, 30 July].

⁷⁴ Graedel, T. (2002). Material Substitution: a Resource Supply Perspective. *Resources, Conservation and Recycling*, 34. pp. 107-115.

⁷⁵ Gabrielsson, Göran. (2002, July 12). The Swedish National Chemicals Inspectorate. *Re: Bly i lödtenn* [Lead in solder].

⁷⁶ The bill was subsequently called the Reid Bill after Senator Reid, who worked hard to eliminate toxic lead exposures to the humans and the environment.

⁷⁷ The U.S. Senate. (1994). *Lead Exposure Reduction Act S.729. Final passage, as amended. 103rd Congress 2nd session*. <http://www.senate.gov/~rpc/rva/1032/1032133.htm> [2002, 18 August].

⁷⁸ Lee, N-C. (2002). *Reflow Soldering Processes and Troubleshooting: SMT, BGA, CSP and Flip Chip Technologies*. p. 251.

⁷⁹ U.S. Environmental Protection Agency. (2001). *Emergency Planning and Community Right-to-Know Act – Section 313: Guidance for Reporting Releases and Other Waste Management Quantities of Toxic Chemicals: Lead and Lead Compounds*. Washington: U.S. Environmental Protection Agency. p.1-1.

into the environment. In January 2001, US EPA lowered the reporting thresholds for lead and lead compounds from 25 000 pounds and 10 000 pounds to 100 pounds.⁸⁰

As of today, there is no specific regulation in the U.S. that bans lead in electronic solders. However, several lead-free initiatives have been set-up by non-governmental organisations (NGO), such as the National Electronics Manufacturing Initiative (NEMI), the Institute for Printed Circuits (IPC) and the International Tin Research Institute.⁸¹ In 2001, the National Electronics Product Stewardship Initiative (NEPSI) was established to form a multi-stakeholder dialogue, involving the electronics industry, government, environmental groups and recyclers. The goal of the NEPSI is to develop a system, based upon extended producer responsibility (in the U.S. more known as product stewardship), “which includes a viable financing mechanism, to maximize the collection, reuse, and recycling of used electronics, while considering appropriate incentives to design products that facilitate source reduction, reuse and recycling; reduce toxicity and increase recycled content”.⁸²

3.2.2 Japan

In 2001, the Consumer Electronics Recycling Law, which requires manufacturers to recover harmful materials, was enacted.⁸³ The law mainly targets four product groups, i.e. TV sets, refrigerators, washing machines and air conditioners. An extension to cover other product types such as PCs is expected in a later phase.⁸⁴

Currently there is no law in Japan leading to or requiring a ban on lead in electronic solder. Nevertheless, the Japanese electronics industry has always been environmentally conscious and lead-free solders have been seen by manufacturers as a marketing opportunity to increase market shares when regulation will ban lead in EEE.⁸⁵ In 2000, the Japan Electronic and Information Technology Industries Association (JEITA) published a roadmap indicating that full use of lead-free solders, in all new products, shall be achieved in 2003 (for more information on the JEITA Roadmap see Table 3-1).

Table 3-1. JEITA’s roadmap for Japanese electronics industry, from 2000, on the phase out of lead in electrical and electronic equipment.

First adoption Pb-free solders in mass produced goods	1999-2000
Adoption of Pb-free components	2000
Adoption of Pb-free solder in wave soldering	2000
Expansion of use of Pb-free components	2001
Expansion of production of Pb-free products	2001
General use of Pb-free solders in new products	2002
Full use of Pb-free solders in all new products	2003
Pb-based solder used only exceptionally	2005

⁸⁰ The earlier reporting thresholds were 25 000 pounds for the total amount of a listed chemical manufactured or processed annually and 10 000 pounds for the total amount of a listed chemical that is otherwise used annually.

⁸¹ Le Fèvre, P. (2002) Environmental Issues in Power Electronics (Lead Free).

⁸² National Electronics Product Stewardship Initiative. (2002). <http://eerc.ra.utk.edu/clean/nepsi/index.htm> [2002, 18 August].

⁸³ Le Fèvre, P. (2002) Environmental Issues in Power Electronics (Lead Free).

⁸⁴ Tojo, Naoko. (2002). EPR in Practise 1: Legislation for Electrical and Electronic Equipment. Handouts from lecture at the Master Programme in Environmental Management and Policy 2001-2002. HIEE. Lund, Sweden. 11March 2002.

⁸⁵ Le Fèvre, P. (2002) Environmental Issues in Power Electronics (Lead Free).

Source: Nimmo 2002.

Strong manufacturing initiatives and an objective to use lead-free solders in full-scale by 2002, combined with strong NGO support has given the Japanese electronics industry a leadership position on the global market. Many manufacturers have already released lead-free components and EEE.

3.2.3 Europe

Within Europe, the Scandinavian countries are known to have been working proactively to phase out lead in various applications. In 1994, Denmark, Sweden, Norway, Finland and Iceland signed a statement to phase out Pb in the long run.⁸⁶ In November 2000, Denmark passed a law on prohibition of import and marketing of products containing lead. The ban is the first of its kind in the world, in that it puts a general ban on lead usage in products.⁸⁷ However, lead in EEE is not regulated by the legislation.⁸⁸

In Europe there are several pending national laws on extended producer responsibility (EPR) for EEE (for more information on the European take-back initiatives on waste EEE see Appendix 1). In July 1998, Switzerland passed the Ordinance on the return, take-back and disposal of electrical and electronic appliances.⁸⁹ In January 1999, the Dutch law entitled *Disposal of white and brown goods decree* came into force.⁹⁰ In January 2000, household appliances, consumer electronics, information and communications technology equipment and others were added to the Dutch decree.⁹¹ In July 1999, Norway's EPR law on scrapped electrical and electronic products was enacted and in July 2001, Sweden followed by introducing its ordinance on producer responsibility on EEE.^{92, 93}

In 1998, the EU proposed a draft directive on EPR on EEE. Two years later, the European Commission adopted two draft directives on Waste Electrical and Electronic Equipment (WEEE) and on the Restriction of the use of certain hazardous substances in Electrical and Electronic Equipment (RoHS). The goal of the directives is firstly to prevent the generation of waste EEE secondly to enhance the reuse, recycling and other forms of recovery of such waste and thirdly, minimize the risks and impacts to the environment from the treatment and disposal of waste EEE. The directives also seek to contribute to the harmonization of national initiatives, taken in this area, to ensure the functioning of the internal market.⁹⁴ In February 2001, the two directives were accompanied by a third proposal on the Impact on the environment of Electrical and Electronic Equipment. The goal of this

⁸⁶ Lee, N-C. (2002). *Reflow Soldering Processes and Troubleshooting: SMT, BGA, CSP and Flip Chip Technologies*. p. 251.

⁸⁷ The law on prohibition of import and marketing of products containing lead does not affect lead usages that have been controlled in earlier legislations, such as lead in fuels and batteries.

⁸⁸ Danish Environmental Protection Agency. (2000) [Online]. *Statutory Order No. 1012 of November 13, 2000, on Prohibition of Import and Marketing of Products Containing Lead*. <http://www.mst.dk/homepage/default.asp?Sub=http://www.mst.dk/chemi/01073300.htm> [2002, 18 August].

⁸⁹ Swiss Agency for the Environment, Forests and Landscape. (1999). *Ordinance on the Return, the Taking Back and the Disposal of Electrical and Electronic Appliances*. http://www.buwal.ch/abfall/docu/pdf/e_vreg.pdf [2002, 18 August].

⁹⁰ NWPM. (1999). *Regulation for Disposal of Electrical Goods in The Netherlands*. http://www.nvmp.nl/html/10_english/01_d_english.htm [2002, 18 August].

⁹¹ CECED. (2002). *Initiatives undertaken by EU Member States and Norway and Switzerland to deal with take-back and proper treatment of waste electrical and electronic equipment (WEEE)*. Status report February 2002. Brussels: CECED. p. 7.

⁹² Norwegian Ministry of the Environment. (1999). *Regulations regarding Scrapped Electrical and Electronic Products*. <http://odin.dep.no/md/engelsk/regelverk/lover/022001-200002/index-dok000-b-n-a.html> [2002, 18 August].

⁹³ Swedish Environmental Protection Agency. (2001). *Waste from Electrical and Electronic Equipment – Coming Regulations in Sweden*. <http://www.internat.environ.se/index.php3?main=/documents/issues/technic/electric.htm> [2002, 18 August].

⁹⁴ Commission Proposal COM (2000) 347 final. p. 5.

directive, which currently has the status of a draft proposal, is to “harmonise the requirements concerning the design of EEE to ensure the free movement of these products within the EU internal market, aiming to improve their overall impact on the environment”.⁹⁵

The WEEE and RoHS directives will have huge impacts on the whole global electronics industry and thus, they have been highly debated. In the following sections, sections 3.3 and 3.4, the WEEE and RoHS directives are covered in more detail.

3.3 The Waste Electrical and Electronic Equipment Directive

On 13 June 2000, the European Commission adopted the proposal for a European Parliament and Council directive on Waste Electrical and Electronic Equipment (WEEE). Currently, the final version of the WEEE directive is being discussed within the European Parliament (EP) and the Council. An EP/Council conciliation will begin in September 2002 to negotiate the final text for adoption. As the conciliation committee has to finish its negotiations within 6 weeks, the earliest date that the directive can be finalised is probably sometime in October or November 2002.^{96, 97} This in turn, would require national legislation to be implemented by 2004 in Member States.⁹⁸

The objective of the WEEE directive is to prevent the generation of EEE wastes, increase reuse, recycling and to reduce the environmental burden associated with end-of-life management of these waste streams. The directive covers a wide scope of EEE products divided into 10 product categories, which are shown in Box 3-1. The directive states that Member States shall ensure that separate collection systems are set up for EEE waste and that proper treatment, recovery and disposal of such waste take place. Producers of EEE are required to take-back consumer end-of-life products free of charge.⁹⁹ “Commercial customers, however, can be charged for this service. Although, still uncertain at this time, collection of WEEE will most likely remain the responsibility of local municipalities to finance”.¹⁰⁰

⁹⁵ European Commission. (2001). *Working paper for a Directive of the European Parliament and of the Council on the Impact on the Environment of Electrical and Electronic Equipment (EEE)*. Version 1.0. February 2001. http://europa.eu.int/comm/enterprise/electr_equipment/eee/workdoc.pdf [2002, 19 August] p.5.

⁹⁶ The WEEE directive shall be implemented in national legislations no later than 18 months after the date of the entry into force of the directive.

⁹⁷ McLoughlin, Aaron. (2002, August 20). European Commission, DG Environment. Telephone interview.

⁹⁸ van Rossem, C. (2001). Environmental Product Information Flow – Communication of the Environmental Data to Facilitate Product Improvement in the ICT Sector. p. 22.

⁹⁹ Commission Opinion COM (2002) 354 final. p. 2.

¹⁰⁰ van Rossem, C. (2001). Environmental Product Information Flow – Communication of the Environmental Data to Facilitate Product Improvement in the ICT Sector. p. 22.

Box 3-1. The categories of electrical and electronic equipment covered by the proposed WEEE directive.

1. Large household appliances
2. Small household appliances
3. IT and telecommunications equipment
4. Consumer equipment
5. Lighting equipment
6. Electrical and electronic tools (with the exception of large-scale stationary industrial tools)
7. Toys, leisure and sports equipment
8. Medical devices (with the exception of all implanted and infected products)
9. Monitoring and control instruments
10. Automatic dispensers

Source: Council Opinion 2001.

Producers have the responsibility to manage EEE waste collected at municipal collection points and by retailers. To create an economic incentive to adapt design changes favourable for sound waste management, treatment, recovery and disposal of waste EEE shall be financed by the producers.¹⁰¹ To ensure compliance with the Waste Framework directive (directive 75/442/EEC), the WEEE directive also includes some minimum treatment requirements. Certified treatment facilities have to remove and separately treat the substances, preparations and components listed in Box 3-2.

Box 3-2. Minimum separation requirements for certified treatment facilities set by the WEEE directive.

- Polychlorinated biphenyls (PCB) containing capacitors
- Mercury containing components, such as switches or backlighting lamps
- Batteries
- PCBs of mobile phones generally, and of other devices if the surface of the PCB is >10 cm²
- Toner cartridges, liquid and pasty, as well as colour toner
- Plastic containing brominated flame retardants
- Asbestos waste
- Cathode ray tubes
- CFC, HCFC or HFCs
- Gas discharge lamps
- Liquid crystal displays of a surface greater than 100 cm² and all those back-lighted with gas discharge lamps
- External electrical cables
- Components containing refractory ceramic fibres and radioactive substances

Source: Council Opinion 2001.

Required treatment methods and recycling quotas are also outlined in the directive. For the separately collected IT and telecommunications equipment and consumer equipment, 75% by weight of the

¹⁰¹ Commission Opinion COM (2002) 354 final. p. 2.

products must be recovered, including a 65% reuse and recycling of the components, material and substances.¹⁰²

Table 3-2 summarises the principal obligations placed on different actors in the EEE life cycle.

Table 3-2. Summary of the principal obligations for the treatment of household waste electrical and electronic equipment placed on different actors by the WEEE directive.

Area	Nature of obligation	Responsible actor (technical and/or financial implementation)	Time frame
Collection	Set up collection facilities & systems (Art. 4.1a)	Public authorities (4.1a);	30 months after directive's entry into force (Art. 4.1)
	Take-back free of charge (Art. 4.1a)	Public authorities (4.1a); distributors [on a one to one basis] (Art. 4.1b)	Idem (Art. 4.1)
	Achieve 6 kg of separate collection per cap/yr. (Art. 4.4)*	Public authorities (Art. 4.4)	36 months after directive's entry into force (Art. 4.4)
	Transfer from collection facilities to treatment facilities (Art. 4.3)	Public authorities (Art. 4.3); financed by producers on a collective or individual basis (Art. 7.2-3)	30 months after directive's entry into force (Art. 7.1); this obligation also applies to historical waste, the financing of which must be shared proportionately by all existing producers (Art. 7.3)
Treatment	Set up treatment systems and provide for treatment (Art. 5.1) in authorized treatment facilities (Art. 5.2)	Financed by producers on collective or individual basis (Art. 7.2-3)	Idem (Art.7.1 & 7.3)
Recovery	Set up recovery systems (Art. 6.1)	Idem (Art. 7.2-3)	Idem (Art. 7.1 & 7.3)
	Achieve minimum recovery (including reuse and recycling) targets for separately collected waste (Art. 6.2)	Idem (Art. 7.2-3)	By 31 December 2005 (Art. 7.2)*; including historical waste (Art. 7.3)
Disposal	Provide for environmentally sound disposal (Art. 7.1)	Idem (Art. 7.2-3)	30 months after directive's entry into force (Art. 7.1); including historical waste (Art. 7.3)

Source: Council Opinion 2001, based upon Table 1 in Economic & Social Committee Opinion 2000. * Updated according to European Commission 2002.

The WEEE directive is based on article 175 of the Treaty establishing the European Community (EC Treaty). Article 175, which states "Community policy on the environment shall aim at a high level of

¹⁰² van Rossem, C. (2001). Environmental Product Information Flow – Communication of the Environmental Data to Facilitate Product Improvement in the ICT Sector. p. 22.

protection taking into account the diversity of situations in the various regions of the Community” that is the article for environmental laws.

The initiative to proceed with a draft directive on WEEE was taken by EU Environment Commissioner Ritt Bjerregaard in July 1997. The decision was based upon a British study on the economic and environmental impacts of waste EEE, carried out by consultancy AEA Technology. The study concluded, “it is technically possible and environmentally beneficial to recycle waste electrical and electronic equipment. It also suggests that the proposed directive should set minimum targets for different product groups, as well as an overall recycling and recovery target for WEEE”.¹⁰³

3.4 Proposal for a Directive on the Restriction of the Use of Certain Hazardous Substances in Electrical and Electronic Equipment

The proposal for a European Parliament and Council Directive on the Restriction on the use of certain hazardous substances in Electrical and Electronic Equipment (RoHS) states that Member States shall ensure that the use of cadmium (Cd), mercury (Hg), lead (Pb), hexavalent chromium (chromium VI) and two brominated flame retardants, polybrominated diphenylethers (PBDEs) and polybrominated biphenyls (PBBs) is banned by 2006. The directive applies to the EEE falling under the categories 1-7 and 10 set out in the WEEE directive (displayed in Box 3-1) and to electric light bulbs and luminaries in households.¹⁰⁴ As for the WEEE directive, the final text of the RoHS directive is currently being discussed and an EP/Council conciliation will begin in September 2002 to finalise the text for adoption.

Originally, the RoHS directive was included in the WEEE directive. However, on 13 June 2000, the European Commission had split the two directives and the RoHS directive was proposed as separate directive based on article 95 of the EU treaty. Article 95 is intended to ensure market harmonization and does not allow Member States to constitute more stringent rules than set by the directive. The reason for the split was mainly “pressure from industry groups and the Commission’s own enterprise and internal market directorates, which had wanted to prevent EU Member States such as Sweden and Denmark from introducing unilateral substance bans”.¹⁰⁵

Applications of lead that are exempted from the RoHS are the following:¹⁰⁶

- Lead in high melting temperature type solders (i.e. tin-lead solder alloys containing more than 85% lead),
- Lead in solders for servers, storage and storage array systems (exemption granted until 2010),
- Lead in solders for network infrastructure equipment for switching, signalling, transmission as well as network management for telecommunications,
- Lead in electronic ceramic parts (e.g. piezoelectronic devices).
- Lead in glass of cathode ray tubes, electronic components and fluorescent tubes

¹⁰³ ENDS Environmental Daily. (September 26, 1997). DGXI planning single electronic waste directive. Issue 153.

¹⁰⁴ Parliament & Council Common Position 2002/C 90 E/02 of 4 December 2001.

¹⁰⁵ ENDS Environmental Daily. (June 13, 2000). EU electroscrap directive finally proposed. Issue 780.

¹⁰⁶ Parliament & Council Common Position 2002/C 90 E/02 of 4 December 2001.

- Lead as an alloying element in steel containing up to 0.35% lead by weight, aluminium containing up to 0.4% lead by weight and as a copper alloy containing up to 4% lead by weight

3.4.1 The Science Behind the Decision to Phase Out Lead in Solders

According to the EU Commission, the reason for banning lead and the other substances covered by the RoHS directive lies upon the associated risks when improperly treated in incinerators or landfills.¹⁰⁷ Although, the WEEE directive sets up separate collection and recycling systems for waste EEE, the soft collection targets only constitute a small fraction of the overall annual generation of this waste, which thereby, requires a ban of the hazardous substances.¹⁰⁸ Consequently, the restrictions on the use of lead in electronics arose from concerns over lead being deposited in landfills and later by leaching from these sources and potentially contaminating land and water supplies. There was also concern pertaining to lead contamination of workers and of the environment due to lead recycling operations.

During the research for this thesis, no information showing that any risk analyses specifically on lead in electronic solders were performed prior to the EU decision to ban lead in solders were found.^{109, 110} Instead, the decision to ban lead seems to be based upon more general studies of the toxicity and environmental fate of lead. According to Gabriëlsson 2002, the EU decision to phase out lead in EEE was predominantly based upon the following three references:¹¹¹

1. Risk Reduction Monograph no. 1: Lead – Background and National Experience With Reducing Risk, OECD, 1993.¹¹²
2. Some uses of lead and their substitutes, KEMI, 1994.¹¹³
3. Public health implications of environmental exposure to cadmium and lead: an overview of epidemiological studies in Belgium, Staessen et al. for CadmiBel and PheeCad Study Groups, 1996.¹¹⁴

Eggert, a scientific co-worker to Karl-Heinz Florenz, the European Parliament, stated that the RoHS directive could be seen as a follow up legislation to the end-of-life vehicles directive (ELV) adopted in 2000, which has similar restrictions on the usage of lead.¹¹⁵ The ELV directive states that Member States shall ensure that materials and components of vehicles put on the market after 1 July 2003 do not contain lead, mercury, cadmium or hexavalent chromium.¹¹⁶ Moreover, due to the preceding ELV

¹⁰⁷ van Rossem, C. (2001). Environmental Product Information Flow – Communication of the Environmental Data to Facilitate Product Improvement in the ICT Sector. pp. 23-24.

¹⁰⁸ Commission Proposal COM (2000) 347 final. p. 20.

¹⁰⁹ McLoughlin, Aaron. (2002, August 20). European Commission, DG Environment. Telephone interview.

¹¹⁰ Klingbeil, Marianne. (2002, August 13). European Commission, Head of Unit, A2, Consumption and Waste. Letter to Ulrika Kindsjö.

¹¹¹ Gabriëlsson, Göran. (2002, July 12). The Swedish National Chemicals Inspectorate. *Re: Bly i lötlenn* [Lead in solder].

¹¹² OECD. (1993). *Risk Reduction Monograph No. 1: Lead – Background and National Experience with Reducing Risk*.

¹¹³ Swedish National Chemicals Inspectorate. (1994). *Some Uses of Lead and Their Possible Substitutes – the use of lead in electronics, building, materials, weights, metal working, professional fishing, and miscellaneous other applications*.

¹¹⁴ Staessen, J., Buchet, J-P., Ginocchio, G., Lauwerys, R., Lijnen, P., Roels, H. & Fagard, R. (1996). Public Health Implications of Environmental Exposure to Cadmium and Lead: an Overview of Epidemiological Studies in Belgium. *Journal of Cardiovascular Risk*. 3, pp. 26-41.

¹¹⁵ Eggert, Axel. (2002, August 16). Scientific Co-worker to Mr. Karl-Heinz Florenz, European Parliament. *Re: RoHS directive*.

¹¹⁶ Council Directive 2000/53/EC of 18 September 2000.

directive, Eggert argues that “there was no doubt that the [European] Commission, EP and [European] Council would agree to ban lead in electronic equipment. Industry was always aware of this but of course tried to get as many exemptions as possible and a later enforcement date (2008)”.¹¹⁷ However, lead used as solder in electronic circuit boards is exempted from the ban in the ELV directive.¹¹⁸

3.4.2 Involved Actors

The movement towards lead-free electronic solders began in May 1990 when the European Council, in its resolution, recommended the Commission to establish an action programme for different types of waste. Member States identified, “end-of-life EEE”, as waste streams that ought to be covered. Subsequently, a European project group on waste EEE was established.¹¹⁹

During the period from January 1994 through July 1995, the project group held meetings, under the command of the Commission and a national environmental department. Representatives from the EU’s and EFTA’s Member States, officials from the Commission, representatives from local governments, suppliers, manufacturers, distributors and companies working within the recycling sector met to discuss the problems faced by EEE waste. Moreover, several international, European and national business organisations were consulted (for a specific list of business organisations see Appendix 2). After extensive discussion, the Commission put forward a proposal for a directive.¹²⁰

The proposal to ban lead in solders has been highly debated. According to Eggert at the European Parliament, industry has lobbied extensively for more exemptions on lead, e.g. in electronic solders. As an example, Eggert mentioned that there had been some amendments in European Parliament’s first reading on the RoHS from British, Irish, Italian and Spanish conservative Members of the European Parliament (MEPs) as well as from British and French socialist MEPs. As a consequence, the EP amended the proposal from the Commission and exempted lead contained in high melting temperature type solders (i.e., tin-lead solders containing more than 85% lead).¹²¹

Besides discussing which lead applications should be exempted, the discussions have principally focused on the date of the entry of the ban. In the Commission’s proposal on 13 June 2000, the date for the ban was set to 1 January 2008. It was stated that as technically and economically viable substitutes of lead in solders had already been confirmed by practical experience of manufacturers, a ban by January 2008 would be possible at reasonable cost.¹²² Later on, the date for the entry of the ban has been moved from 2008 to 2007 to 2006, as it has been concluded that alternative products are already available which consequently, gives industry enough time to adapt to an earlier enactment date.

Strong opposition against the decision to ban lead in solders has particularly come from companies and organisations in the U.S. The American Electronics Association (AEA) and the EIA have stated that the directives “may, in the long-run, cause more harm than good because they are not based on any environmental analysis and may fail to promote...an efficient recycling infrastructure across the EU”. The organisations have also stated that the plan to ban lead, and mercury and cadmium, is of particular

¹¹⁷ Eggert, Axel. (2002, August 16). Scientific Co-worker to Mr. Karl-Heinz Florenz, European Parliament. *Re: RoHS directive*.

¹¹⁸ Council Directive 2000/53/EC of 18 September 2000.

¹¹⁹ Klingbeil, Marianne. (2002, August 13). European Commission, Head of Unit, A2, Consumption and Waste. Letter to Ulrika Kindsjö.

¹²⁰ Klingbeil, Marianne. (2002, August 13). European Commission, Head of Unit, A2, Consumption and Waste. Letter to Ulrika Kindsjö.

¹²¹ Eggert, Axel. (2002, August 16). Scientific Co-worker to Mr. Karl-Heinz Florenz, European Parliament. *Re: RoHS directive*.

¹²² Commission Proposal COM (2000) 347 final. p. 53.

concern as it “may result in a negative environmental impact by forcing adoption of substitutes that could have a more detrimental impact than the substances they replace”.¹²³

¹²³ ENDS Environmental Daily. (September 6, 2000). US firms lobby Gore over EU electroscrap plans. Issue 826.

4. Recycling of PCBs/EEE waste

Solder only constitutes a small fraction of the PCBs, which in turn makes up a fraction of the total amount of waste EEE. The Nordic Council of Ministers estimated, based upon a Scandinavian study, that PCBs make up about 3.1 wt% of the waste EEE generated.¹²⁴

Due to limited information available for solder in EEE, the estimations, in this thesis, of the fate of solder in the end-of-life treatment and in recycling activities have several limitations. To understand the fate and treatment of solder, a general overview of the amount of EEE waste generated and the management of this waste is first given in this chapter. Thereafter, this chapter explores current recycling activities with a focus on the treatment of printed circuit boards, which contain the solder.

4.1 The Fate and Amount of Waste of EEE

4.1.1 EU

The European Commission estimated that in 1998, six million tons of wastes from EEE were generated in the EU. In addition, an average annual growth rate of 3-5% is expected for EEE waste, which is about three times higher than the growth of the average municipal waste.^{125, 126} During the thesis work, no statistics on the fate of EEE waste for the EU have been obtained. However, the European Topic Centre on Waste and Material Flows has made projections on quantities of WEEE in a report that will become available to the public in October or November 2002.¹²⁷ Consequently, during the research, none of the information presented in the report was available to the author.

In Sweden, where an EPR legislation was enacted in July 2001, the annual amount of EEE waste generated is estimated to exceed 200 000 tons.^{128, 129} This translates into approximately 22.4 kg/year per capita, which corresponds well with the quantities in the EU of 19.8 kg/year per capita.^{130, 131} In 1995, the Nordic Council of Ministers estimated that the EEE waste will be between 20 and 25 kg/year per capita during the nineties, which also corresponds well with the above figures.¹³² According to the Swedish EPA, a total amount of about 41 500 tons (or about 83 000 tons per annum) of EEE waste were separately collected during a six month period, starting on the enactment of the EPR legislation

¹²⁴ Taberman, S-O., Carlsson, B., Erichsen, H., Legarth, J., & Gregersen, Johan C. (1995). *Environmental Consequences of Incineration and Landfilling of Waste from Electr(on)ic Equipment*. TemaNord 1995:555. Copenhagen: Nordic Council of Ministers. p. 29.

¹²⁵ Commission Proposal COM (2000) 347 final. p. 4.

¹²⁶ European Environmental Bureau (EEB). (2001). *Towards Waste-Free Electrical and Electronic Equipment: EEB argumentation paper concerning the proposal for Directives on Waste Electrical and Electronic Equipment and on the Restriction of the use of certain Hazardous Substances in Electrical and Electronic Equipment*. p. 3.

¹²⁷ Jacobsen, Henrik. (2002, August 19). ETC Data Manager, European Topic Centre on Waste and Material Flows. Re: *Recycling of scrap electronics*. E-mail to Ulrika Kindsjö.

¹²⁸ Swedish Environmental Protection Agency. (1995). *Electronic and Electrical Equipment – The Basis for Producer Responsibility*. Report 4406. Stockholm: Swedish Environmental Protection Agency. p. 12.

¹²⁹ Berglund, Christina. (2001). *End of Life Treatment Requirements of Materials Content for Electronics*. Thesis 2001:15. Stockholm, Industriellt Miljöskydd, Royal Institute of Technology. p. 5.

¹³⁰ The Swedish figure of 22.4 kg/year per capita was calculated by the author (total amount of EEE waste generated in Sweden in 2001 = 200 000 ton, population in 2001 = 8 909 128).

¹³¹ The EU figure of 19.8 kg/year per capita was calculated by the author (total amount of EEE waste generated in EU in 1998 = 6 million ton, population in 1998 = 300 962 384).

¹³² Taberman, S-O., Carlsson, B., Erichsen, H., Legarth, J., & Gregersen, J. (1995). *Environmental Consequences of Incineration and Landfilling of Waste from Electr(on)ic Equipment*. p. 24.

on July 1, 2001 (for more details see Table 4-1). Rough estimations, completed by the author, gave a recycling figure for Sweden of 46%. However, this figure is very uncertain as the data for the total amount of EEE waste collected has not been officially confirmed and should therefore, only be interpreted as a guesstimate. To the best knowledge of the author, no official data for the fate of EEE waste, i.e. how much is recycled, incinerated and deposited in comparison to the total amount generated, exist in Sweden today.

Table 4-1. Separately collected EEE waste in Sweden, since the enactment of the EPR legislation in July 2001.

Product group	Amounts Collected ¹ (tons per annum)
Household appliances (excl. refrigerators & freezers)	28 302
IT & office equipment (incl. medical and laboratory equipment)	7 716
Telecommunication equipment	90
Television sets, radio, and video sets	13 594
Cameras	50
Watches	14
Toys	36
Lighting equipment	5 360
Others	1 588
Warehouse storage, not treated	4 000
Equipment collected by ÅI ²	22 220
Total amount	82 970
Total per capita per year	~10 kg

¹ The values are extrapolated from the collection period of July 1 to December 31, 2001. ² Återvinningsindustrierna (ÅI) [The Swedish Recycling Industries' Association] Source: Swedish Environmental Protection Agency 2002.

The Ministry of Housing, Spatial Planning and the Environment estimated in The Netherlands, that 134 000 tons of EEE waste, equivalent to 8.3 kg/year per capita, is discarded yearly.¹³³ Of that 4 kg/year per capita, equivalent to 48% is estimated to be separately collected and recycled.¹³⁴ In Norway, it has been estimated that in total 29.2 kg of EEE waste is generated per year per capita, of which 13.16 kg were collected per person in 2001, equivalent to a recycling rate of 45%.¹³⁵

As stated previously, no explicit figures for the distribution of EEE waste among recycling, incineration and landfilling within the EU or Europe has been found. To summarise, it can be said that separate waste management systems of EEE waste are still in their infancy and most EEE waste is probably still deposited in landfills or treated via incineration. However, a profitable market on recycling of EEE waste is growing. The distribution between landfilling and incineration of EEE waste not destined for recycling activities is even more unclear than the figure for how much is recycled. Rough estimations of the distribution between landfilling and incineration can be made based upon the

¹³³ Ministry of Housing, Spatial Planning and the Environment. (2001). *Electrical and Electronic Equipment – Waste in the Netherlands* http://www2.minvrom.nl/Docs/internationaal/14285_174elericalequipme.pdf [2002, 23 August]

¹³⁴ CECED. (2002). *Initiatives undertaken by EU Member States and Norway and Switzerland to deal with take-back and proper treatment of waste electrical and electronic equipment (WEEE)*.

¹³⁵ Gronn Hverdag – Miljøheimet. (2002). *El-returtesten 2002: Kilo el-avfall levert per innbygger i 2001* [Kilogram of EEE waste per capita in 2001] <http://www.gronnguide.no/artikkel.php?id=901> [2002, 8 September]

fate of municipal waste generated, however this assumes that the EEE waste follows the same fate as municipal waste, which might be questioned.

Figure 4-1 gives an overview of the distribution of EEE waste destined for the different waste treatments within Europe. As can be seen in the figure, the fate of the waste varies much from country to country. Consequently, it might not be accurate to make any more assumptions based upon the data without further investigation specifically on the fate of EEE waste. However, what can be stated is that incineration and landfilling still make up large EEE waste streams and thus, both ways should be considered when discussing the full environmental impacts of the metals contained in electronic solders at the end-of-life stage.

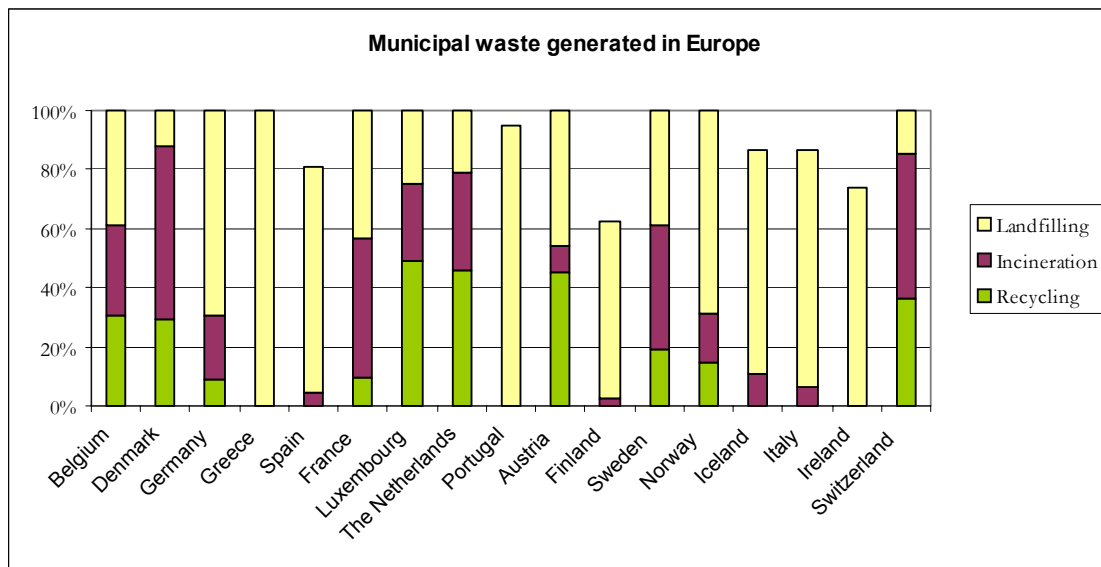

Figure 4-1. Municipal waste generated in Europe. Data 1985-1997. Source: Jacobson 2002.

4.1.2 The U.S.

In the U.S., the National Safety Council reported that in 1998 more than 20 million desktop personal computers became obsolete. Of this, only about 11 percent of the units were recycled and another 3 percent were refurbished and resold or donated.¹³⁶ Four years later, the U.S. EPA's Office of Solid Waste and Emergency Response estimated that in 2000, a total of 1 927 260 tons¹³⁷ of waste of consumer electronics were generated.^{138, 139} As shown in Table 4.2, 193 700 tons or 9% of the generated consumer electronics were estimated to be recovered.

¹³⁶ National Safety Council. (1999). *Electronic Product Recovery and Recycling Baseline Report – Recycling of selected Electronic Products in the United States*. Washington: National Safety Council's Environmental Health Center p. 28.

¹³⁷ 1 927 260 metric ton is equivalent to 2 124 400 American ton.

¹³⁸ Note that the figures for the EU and Norway include EEE waste such as large and small household waste that is not covered in this consumer electronics category.

¹³⁹ Consumer electronics include products "used in residences and commercial establishments such as businesses and institutions. Consumer electronics include video and audio equipment and information age products. Video products include standard televisions (TV), high density TV, liquid crystal display TV, VCR decks, camcorders, laserdisc players, digital versatile disc players, and TV/personal computers (PC). Audio products include rack audio systems, compact audio systems, portable compact discs (CD), portable headset audio, total CD players, and home radios. Information products include cordless/corded telephones, wireless telephones, telephone answering machines, facsimile (fax) machine, word processors, personal computers, computer printers, computer monitors, modems, and fax modems" (U.S. EPA 2002, pp. 47-148).

Table 4-2. Generation, recovery and discards of consumer electronics in the municipal waste stream in the U.S. in 2000.

Type of consumer electronics	Total generation (tons)	Total recovery (tons)	Recovered (%)	Total discards (tons)
Video products	859 300	1 200	0.1	858 100
Audio products	348 200	0	-	348 200
Information products	916 900	192 500	21	724 400
Total	2 124 400	193 700	9	1 930 700

Source: U.S. Environmental Protection Agency 2002.

To be able to estimate the fate of the EEE waste in the U.S., meaning how much is recycled, landfilled and incinerated, the author of this thesis tried to contact the Environmental Departments in each state. However, in most states figures for how much EEE waste was generated and the fate of this waste are not available. Instead, the fate was estimated based upon the figures given in the U.S. EPA's (2002) report *Municipal Solid Waste in the United States: 2000 Facts and Figures*. Consequently, as can be seen in Table 4.3, 2 124 400 tons of EEE waste were generated in 2000 of which 9% was recycled. The report also stated that in 2000, a total of 231.9 million tons of municipal solid waste (MSW) was generated in the U.S. Of this, 55.3% was landfilled, while 14.5% of the waste was incinerated. The remaining waste was either recovered for recycling or composted (see Figure 4-2).¹⁴⁰

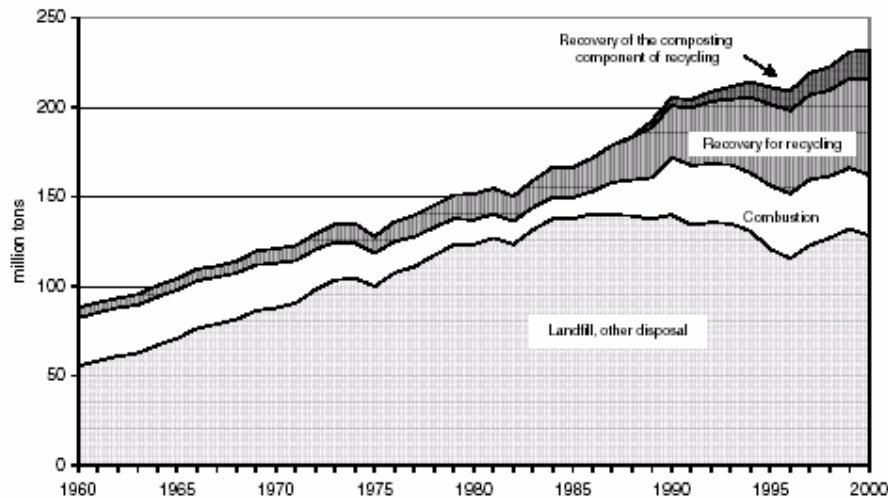

Figure 4-2. Municipal solid waste management in the U.S. from 1960 to 2000. Source: U.S. Environmental Protection Agency 2002.

Based upon the fate of the MSW, 19% and 72% of the remaining EEE waste was incinerated or landfilled respectively.¹⁴¹ However, it should again be explicitly stated that these figures are based upon

¹⁴⁰ U.S. Environmental Protection Agency. (2002). *Municipal Solid Waste in the United States: 2000 Facts and Figures* <http://www.epa.gov/epaoswer/non-hw/muncpl/report-00/report-00.pdf> [2002, 13 August]. pp. 121-124.

¹⁴¹ It was estimated that the remaining 91% of the waste of EEE was either landfilled or incinerated. This waste stream was assumed to follow the fate of MSW meaning that the division between incineration and landfilling will be the same as for MSW (14.5 incinerated to 55.3 landfilled).

the assumption that the waste of EEE follows the same fate as MSW. Moreover, the debated export of waste of EEE has been excluded. In February 2002, the Basel Action Network (BAN) and Silicon Valley Toxics Coalition (SVTC) reported that as much as 80% of the waste of EEE destined for recycling is exported to countries like China, Pakistan and India where the waste is treated in very hazardous ways. However, during this study it has not been possible to obtain any validation of the percentage given in the report, though it has been mentioned that the figure of 80% is not representative for the current situation because EEE waste now has a market value within the U.S.

Table 4-3. The fate of EEE waste in the U.S., estimated based on data from 2000.

	Generated (tons)	Recycled (%)	Landfilled (%)	Incinerated (%)
Waste of EEE in the U.S.	2 124 000	9	72	19

4.2 Collection and Dismantling

The EEE waste, separately collected to be recycled, will, as a first step, be transported to some sort of dismantling facility. In this context it should be noted that in countries/areas where dismantling facilities are not currently operational, some large EEE waste products will still be collected for metal recovery at traditional scrap merchants that usually collect items such as stoves and refrigerators. However, these activities lie outside the scope of this thesis, mainly because they do not separately treat and recycle PCBs or solders.

At dismantling facilities, the EEE waste is dismantled manually with the help of pneumatic and electrical tools. It is typical that the dismantling facilities separate the EEE waste into a number of fractions. At Stena Technoworld in Bräkne-Hoby, Sweden, which is a well-known Scandinavian material recovery centre, the EEE waste is divided into some 70 different fractions. Incoming EEE waste is firstly divided into five general fractions, i.e. large metal parts, PCBs, packaging materials, plastic parts and CRT, before further division and treatment of the separate fractions take place.¹⁴² Figure 4-3 gives an overview of the main material fractions separated at Stena Technoworld and the fate of these streams.

¹⁴² Stena Technoworld. (2002). Processen [The process]. [Online]. Available: http://www.stenametal.se/technoworld/processen/index_processen.htm [20 August 2002].

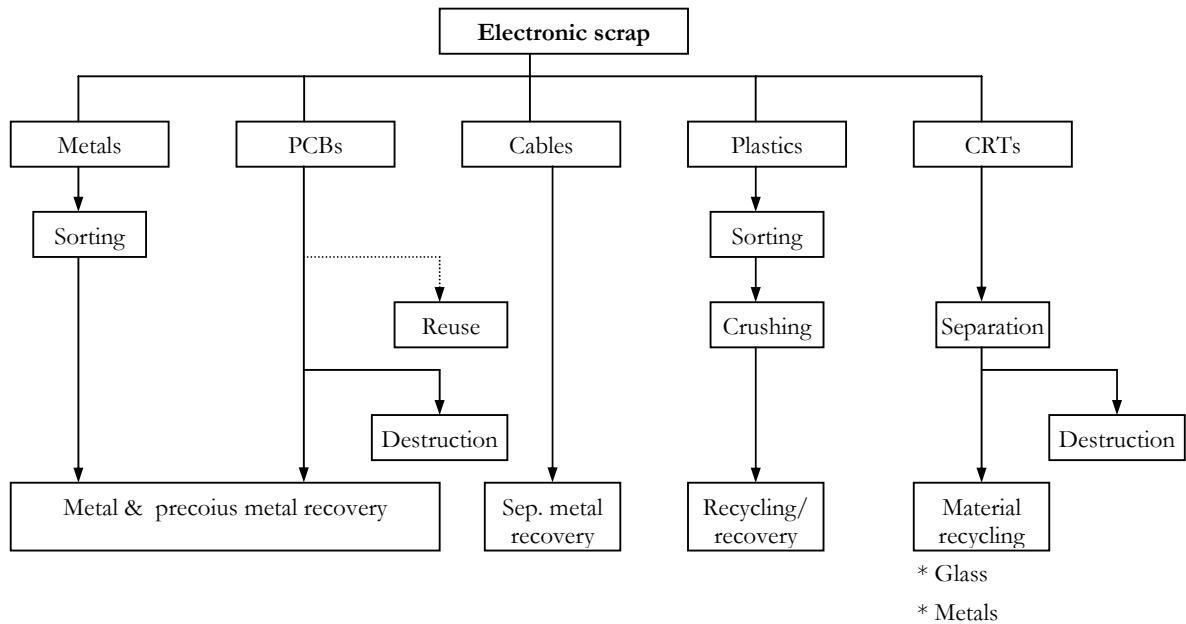

Figure 4-3. The main material fractions separated at Stena Technoworld, Sweden, which is a large dismantling company for EEE waste. Source: Sjölin 2002.

In the dismantling step, reusable components such as memory chips and integrated circuits are removed from the PCBs for resale. Hazardous components, e.g. mercury switches, nickel-cadmium batteries and polychlorinated biphenyl containing capacitors, are also removed from the PCBs. As can be seen in Figure 4-3, the line from separated PCBs to reuse, which symbolises the pathway for reusable components, is only dotted. The reason for this has to do with an indirect consequence of the newly enacted EPR legislation in Sweden. After enactment, the electronic producers and importers decided, through their producer responsibility organisation (PRO) *Elkerfetsen*, that no truly valuable components are allowed to be separately collected from EEE waste for the purpose of reuse. The components that are still permitted to be reused, do not support a profitable market and consequently the amounts of reused components have gone down in Sweden.¹⁴³ The rationale behind the producers' decision to heavily restrict what components are allowed to be recycled is, according to the author, that the producers seek to reduce the competition between newly produced and recycled components.

PCB fractions are normally divided into different fractions based upon the content of precious metals. High value fractions contain separated PCB fractions with a high content of precious metals e.g. computer PCBs. Low value fractions contain low amounts of precious metals, e.g. PCBs in TVs and video recorders. Low value fractions normally contain PCBs and their casings, as it is not profitable to manually separate the PCBs from the casings. Both high and low value fractions will go through the same treatment steps.

The PCB fractions separated at dismantling facilities are thereafter shredded onsite or sold directly to copper/lead smelters for copper and precious metal refinery.¹⁴⁴ Another possible route for the PCB fractions is that the fractions are bought by shredding/processing companies, that, in turn, sell the shredded materials to the smelters.

The shredding/processing companies often accept smaller quantities of EEE waste than the smelters, which could be beneficial for small dismantling actors. Another function that shredding/processing companies can provide is that they can separate some of the material contained, to increase the value of

¹⁴³ Sjölin, Sverker (2002, August 22). Environment and Process Manager, Stena Technoworld. Telephone interview.

¹⁴⁴ Rusk, Bertil. (2002, August 14). Ragnsell. Telephone interview.

low value fractions. At the shredding/processing facility of Arvamet in Skelleftehamn, Sweden, a shredding process is used that separates aluminium and iron. The electronic fractions are shredded in a ring-mill; the iron-containing fractions are then separated by using a magnet. The aluminium fractions are thereafter, separated by applying an electric current that makes the aluminium temporarily magnetic so that it can also be separated with a magnetic force.¹⁴⁵

4.3 Metal Recovery

Copper smelters process PCB waste to recover copper (Cu), gold (Au), silver (Ag), platinum (Pt) and palladium (Pd). From an economic viewpoint, PCB waste is seen as a precious metal source, which is the reason that the smelters receive and process this type of waste. Copper, in itself, is normally seen as a usable by-product that comes along with the precious metals.

On the global market, there are only four large copper smelters that process EEE waste including PCBs, i.e. the following:

- Boliden, Rönnskärsverken, in Skellefteå, Sweden,
- Noranda, Rouyn-Noranda, in Quebec, Canada,
- Umicore, Hoboken, in Antwerp, Belgium, and
- Norddeutsche Affinerie (NA), in Hamburg, Germany.

Although, there are more than 160 copper smelters in the world, of which some process copper scrap these mainly treat waste products with high percentages of pure copper such as electrical cables and copper rods and tubs.¹⁴⁶ However, some smaller copper smelters in Asia, mainly in Japan, China and India, might also process PCBs, however according to Henriksson and Berglund, these smelters normally do not stay on the market for very long.^{147, 148}

Boliden

Currently, Rönnskärsverken (Boliden) recycles about 30 000 tons of EEE waste scrap per year of which some 2 000 tons come from Sweden while the rest is imported.¹⁴⁹ According to Henriksson, who is in charge of purchasing EEE waste at Boliden, PCBs constitute about 50-60% of the total amount processed.¹⁵⁰ In 2000, Boliden produced approximately 240 000 tons of copper, in the form of copper cathodes, of which about 30 % came from recycled materials such as electronic and metal scrap, residues and slag. Additionally, about 40% of the 14kg gold produced and 90% of the 41 000 tons of zinc clinkers produced also came from recycled materials.¹⁵¹

¹⁴⁵ Axelsson, Anders. (2002, September 2). Market Engineer, Arvamet. Personal interview.

¹⁴⁶ Berglund, Christina. (2001). End of Life Treatment Requirements of Materials Content for Electronics. pp. 7-8.

¹⁴⁷ Henriksson, Hans. (2002, July 5). Purchase of EEE waste, Boliden. Telephone interview.

¹⁴⁸ Berglund, Christina. (2001). End of Life Treatment Requirements of Materials Content for Electronics. p. 8.

¹⁴⁹ Swedish EPA]. (2002). *Samla in, återvinn! Uppföljning av producentansvaret för 2001, men också mycket mer...* [Unofficial translation by the author: Collect, recycle! Follow-up of the producer responsibility in 2001, but also much more...]. Report 5237. Stockholm: Swedish Environmental Protection Agency. p. 92.

¹⁵⁰ Henriksson, Hans. (2002, July 5). Purchase of EEE waste, Boliden. Telephone interview.

¹⁵¹ Boliden. (2002b). *Rönnskär 2002* <http://www.boliden.ca/Ronnskar/pdf/Ronnskar2002.pdf> [2002, 20 August].

Noranda

Currently at the Noranda's copper smelter, the Horne smelter, in Rouyn-Noranda, Quebec, Canada, approximately 150 000 tons of metal recyclables is processed annually, of which 50 000 tons is waste of EEE.¹⁵² In 1999, the copper production was 200 000 tons of which 15% came from recycled electronic and metal scrap.¹⁵³ The Horne smelter produces copper anode, which are sent to Noranda's CCR refinery in Montreal-East, Quebec, for the final refinery of copper, into copper cathodes, and of precious metals.¹⁵⁴

Umicore

Umicore's facility in Hobroken, Belgium, under the head of the business unit Umicore Precious Metals, processes copper, lead and nickel containing materials to recover those metals and precious metals.¹⁵⁵ In 2001, 96% of the raw materials processed were secondary material, of this about 16 000 tons were EEE waste.^{156, 157}

Norddeutsche Affinerie

Norddeutsche Affinerie, Hamburg, Germany processes about 4 000 tons of EEE waste, which almost exclusively consists of PCBs. The yearly production of copper is approximately 370 000 tons.¹⁵⁸

4.4 Description of the Process of Refining Copper and Precious Metals from EEE

PCBs are processed by a so-called pyrometallurgical process, meaning that the material is processed in high-temperature reactions to separate metals from impurities. In general, the extraction of metals from PCBs is a complex process, integrated with several process lines to refine various primary and secondary metals.

Figure 4-4 shows some of the complexity at Boliden's copper smelter, where process lines for extracting copper, lead, zinc and precious metals are integrated. As can be seen in the figure, electronic scrap enters the process in a so-called Kaldo plant. Thereafter, it will follow the copper flow to the converter aisle and from there to the anode casting plant, followed by the electrolytic refinery.

¹⁵² Thomas, Cindy. (2002, July 10). Manager Recycling, Noranda Inc. *Re: Recycling of electronic scrap*. E-mail to Ulrika Kindsjö.

¹⁵³ Berglund, Christina. (2001). End of Life Treatment Requirements of Materials Content for Electronics. p. 10.

¹⁵⁴ Noranda Metallurgy Inc. (?). Noranda Recycling. Company Booklet.

¹⁵⁵ Wesseldijk, Quierine. (2002, September 6). Manager Raw Materials Supply – Recycling, Umicore Precious Metals. *Re: Smelting process*. E-mail to Ulrika Kindsjö.

¹⁵⁶ Umicore. (2002). Environment and Safety Report 2001. p. 46.

¹⁵⁷ Umicore. (2002). Annual Report 2001. p. 31.

¹⁵⁸ Gerhart, Sandra. (2002, August 2). Public Relations, Norddeutsche Affinerie AG. *Re: Recycling of PCB*. E-mail to Ulrika Kindsjö.

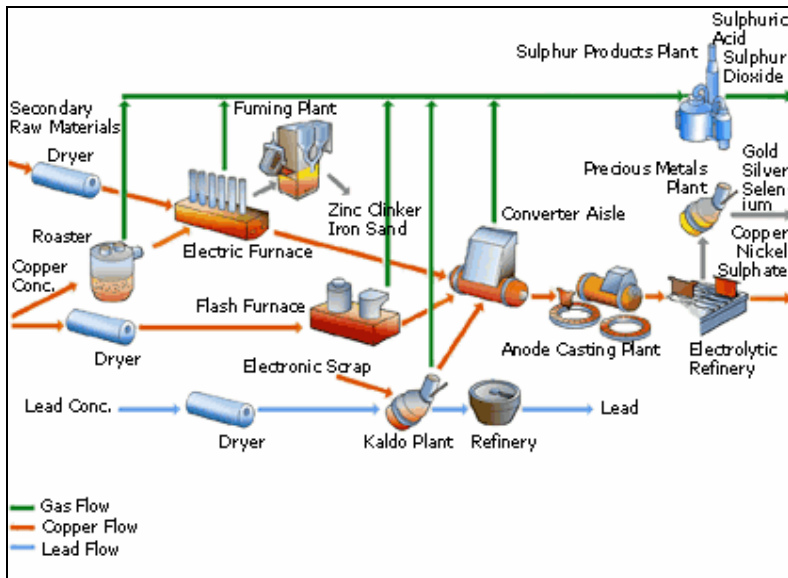

Figure 4-4. The extracting processes for copper, lead, zinc, and precious metals at Boliden, Rönnskär. EEE waste are smelted in the Kaldo furnace, a lead furnace, before the materials are further processed in the converter aisle, which belongs to the copper processing line. Source: Boliden 2000.

In the following section a description, predominately based on information from Boliden and to some extent Noranda, which have quite similar processes, of the steps involved in processing PCBs are given. Figure 4-5 shows a simplified flow map of the steps involved in processing PCBs (for a more detailed flow map see Appendix 3).

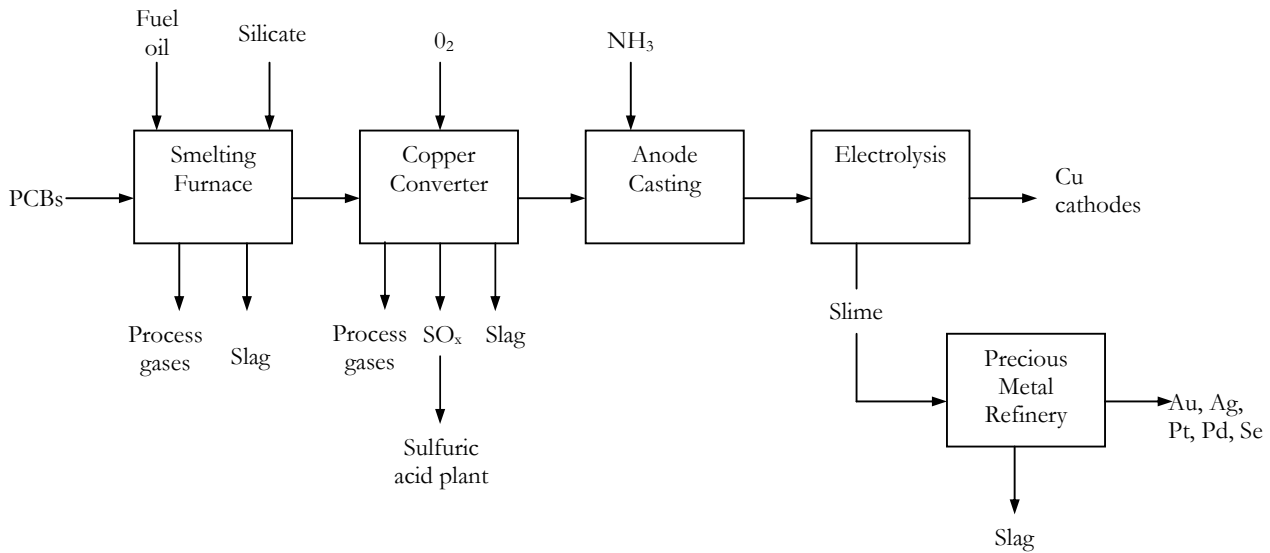

Figure 4-5. Metal recovery process of PCBs, showing the various materials in- and outflows in the different steps.

4.4.1 Sampling

Prior to unloading the shipments, going into the smelters, are checked for radiation. Thereafter, the material is unloaded and sampled to define the metal values and to check for unwanted impurities and dangerous substances such as mercury, bismuth, antimony and polybrominated flame retardants that may disturb the processes. The material is melted, crushed and ground to a fine, homogenous powder before it is analysed. A description of the sampling process at Noranda is given in Figure 4-6.

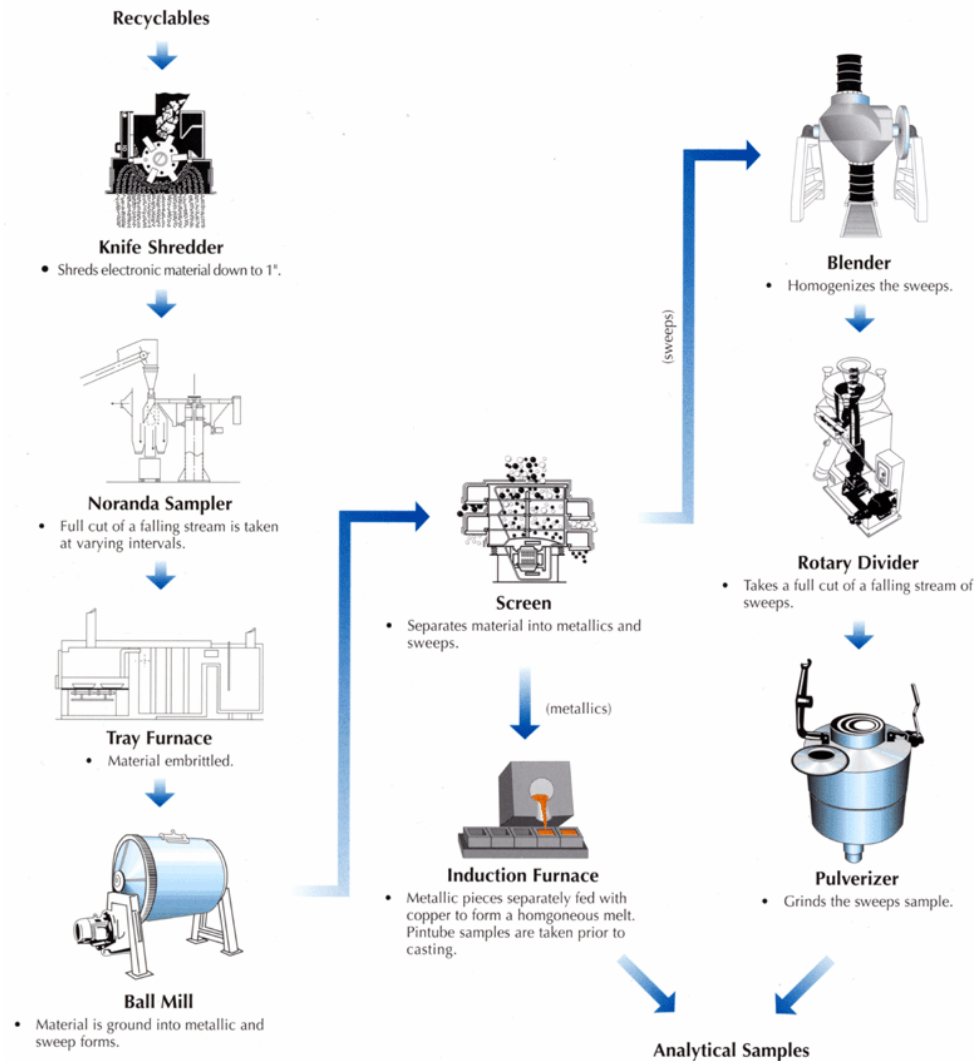

Figure 4-6. Sampling of EEE waste coming into Noranda. Source: Noranda Metallurgy Inc.

The sellers of the electronic scrap are paid by the smelters; based upon the content of precious metals and copper. For certain elements and unwanted impurities, the copper smelters charge economic penalty levels, i.e. when the content of some materials exceed a certain percentage, and maximum acceptable threshold levels.¹⁵⁹ During the research, contacts with representatives from the different smelters were made to ascertain if the copper smelters have any threshold values for lead, tin, bismuth, copper and silver. In common for the smelters, bismuth is accepted in small amounts but with high penalty levels. Lead is also accepted in small amounts, with penalties above certain levels, however lead

¹⁵⁹ Berglund, Christina. (2001). End of Life Treatment Requirements of Materials Content for Electronics. pp. 16-17.

is still accepted in much larger amounts than bismuth. For tin, copper and silver, there seems to be no penalty levels. During the research, no exact figures for when the penalties are charged were provided, due to company secrets. In a thesis by Berglund, from the Royal Institute of Technology, Stockholm, Sweden, from 2001, threshold values for maximum acceptable weight and economic penalty levels of elements in electronic scrap were identified for Boliden, Umicore and Noranda. These values are presented in Table 4-4. However, the penalty levels and maximum levels for bismuth seem to be very low compared to the finding of this thesis that shows that PCBs, in average, contain about 0.17% bismuth (see Table 4-5). This issue was raised during an interview with Henriksson at Boliden, who did not want to comment upon the penalty levels that Boliden charges. However, he thought that a bismuth content of 0.17% in PCBs was representative for PCBs containing the currently used tin-lead solder.¹⁶⁰ Thus, the values in Table 4-4 should be interpreted with some scepticism. In general, it can be said that current amounts of lead contained in tin-lead solder are not high enough to generate any penalties.¹⁶¹ In contrast, if lead is substituted with bismuth, the levels of bismuth will most definitely be above the penalty levels.

Table 4-4. Threshold values for penalty and maximum allowed levels of Bi, Pb and Sn in electronic scrap that the copper smelters Boliden, Umicore and Noranda hold against their suppliers.

	Boliden		Umicore		Noranda ¹	
	Penalty	Max	Penalty	Max	Penalty	Max
Bismuth	>0.001%	0.01%	>0.01%		ALAHP ²	
Lead	>3%	10%			ALAP ²	
Tin						AWP ²

¹ Noranda did not want to give out specific value on threshold levels.

² The meaning of the Noranda abbreviations used in the table are the following; ALAHP = Acceptable in small amounts with high penalty, ALAP = Acceptable in limited amounts with penalty and AWP = Acceptable without penalty.

Source: Berglund 2001.

Material Composition of Printed Circuit Boards

The composition of PCBs can vary, considerably, depending upon the type of application the boards have been produced for, how populated they are and what types of components are attached. In Figure 4-7, general data for what a PCB can contain are given. Table 4-5 gives a more detailed summary of the composition of the elements in a PCB.

¹⁶⁰ Henriksson, Hans. (2002, September 13). Purchase of EEE waste, Boliden. Telephone interview.

¹⁶¹ Axelsson, Anders. (2002, August 15). Market Engineer, Arvamet. Telephone interview.

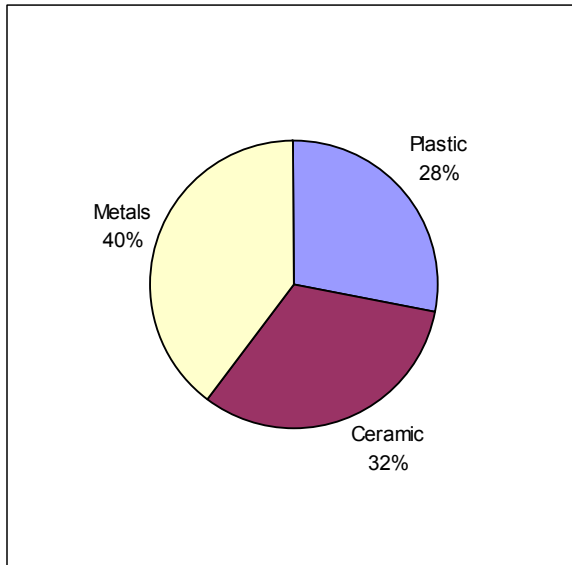

Figure 4-7. Average material composition of PCBs, divided into the three main fractions i.e. metals, plastics and ceramics. Source: Zhang 1999.

Table 4-5. Composition of elements, by weight, contained in a PCB. g/t = grams per metric ton.

H																He	
Li	Be											B	C	N	O	F	Ne
	1.1g/t												9.6%			0.094%	
Na	Mg											Al	Si	P	S	Cl	Ar
												4.7%			0.10%	1.74%	
K	Ca	Sc	Ti	V	Cr	Mn	Fe	Co	Ni	Cu	Zn	Ga	Ge	As	Se	Br	Kr
		55g/t	3.4%		0.05%	0.47%	5.3%		0.47%	26.8%	1.5%	35g/t		0.01%	41g/t	0.54%	
Rb	Sr	Y	Zr	Nb	Mo	Tc	Ru	Rh	Pd	Ag	Cd	In	Sn	Sb	Te	I	Xe
	10g/t		30g/t		0.003%					0.33%	0.015%		1.0%	0.06%	1g/t	200g/t	
Cs	Ba	La	Hf	Ta	W	Re	Os	Ir	Pt	Au	Hg	Tl	Pb	Bi	Po	At	Rn
	200g/t									80g/t	1g/t		1.5%	0.17%			

Source: Lehner & Vikdahl 1998, Lehner 2002.

4.4.2 Smelting

After the incoming fractions of PCBs have been sampled, they are placed in piles until they are to be smelted. Material from the various piles is then combined to form a stable feed into a rotary furnace. In Boliden, a so-called Kaldo furnace is used and in Noranda a process reactor is used. The Kaldo furnace is a lead furnace also used to smelt lead ore. Approximately, half of the operation time the furnace is run on electronic scrap. The purpose of the furnace is mainly to smelt the electronic fractions and to reduce the volume by burning of the plastics (Figure 4-8 illustrates the Kaldo furnace in Boliden).

The process temperature is about 1 200 to 1 250°C. As PCBs contain some 35 to 36 GJ/ton, the smelting process is run on the plastic content of the feed. Thus, after start-up, when fuel oil is added, the process is running on itself, maintained on the energy contained in the organic fraction of the PCBs.¹⁶²

¹⁶² Lehner, Theo. (2002, September 2). Manager Research and Development., Boliden. Personal interview.

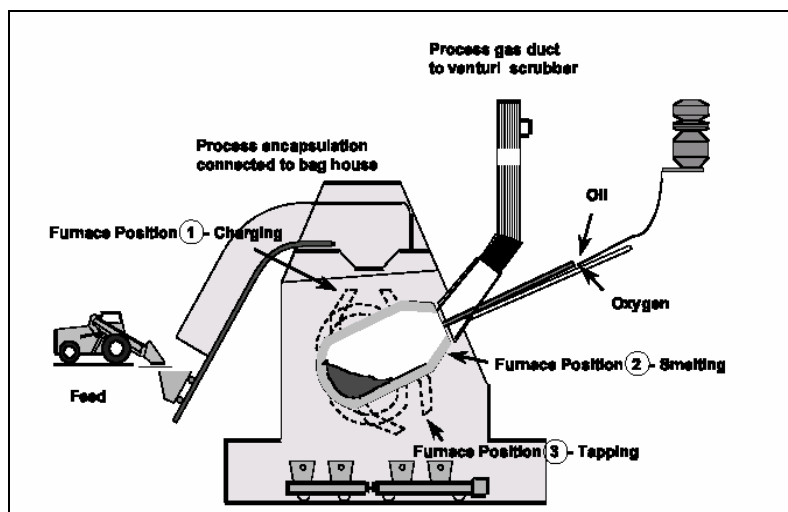

Figure 4-8. Boliden's Kaldo furnace used to process EEE waste. Source: Mark & Lehner 2000.

There are two process steps involved that are exothermic¹⁶³, i.e. the combustion of plastics and the oxidation of aluminium metals. To control the temperature so that it does not become too high, FeO-SiO₂ is added to form aluminium hydroxides, in the same time as the amount of plastics going in with the feed is also controlled.

During the smelting process, two layers are formed, a top layer of slag and a bottom layer of so-called black copper. The black copper is fed into the copper converter with some of the slag. The remaining slag is subsequently transferred to the mining area where it, together with mined ore, is processed through a flotation step to recover some of the precious metals and copper remaining in the slag. Finally, the rest of the slag is deposited in tailings impoundment areas.^{164, 165} The recovered precious metals and copper follow the concentrated ore and are fed into a flash furnace (see Figure 4.4), which processes copper ore, to be further processed.¹⁶⁶

The process gases from the Kaldo furnace are after burnt at 1200-1400°C with a residence time of at least one second. The gases are then purified by shock cooling¹⁶⁷ in a venturi scrubber.¹⁶⁸ The process water, from the scrubber, is thereafter treated in an on-site wastewater treatment plant in a three-step process. Firstly, the water is thickened and the sludge is fed back into the copper line. Secondly, sulphur is added to precipitate metal sulphides, which are also fed back to the copper line. Finally, CaO is added to trap fluorine (F), before the treated water is emitted into the surrounding waters.

After being processed through the venturi scrubber, the gases are treated in a cyclone to trap water droplets and particles. In the final step the gases are treated with active carbon and calcium oxide in a filter station.

¹⁶³ Exothermic meaning that they generate heat.

¹⁶⁴ Henriksson, Hans. (2002, July 5). Purchase of EEE waste, Boliden. Telephone interview

¹⁶⁵ Noranda Metallurgy Inc. (?). Noranda Recycling.

¹⁶⁶ Lehner, Theo. (2002, September 2). Manager Research and Development, Boliden. Personal interview.

¹⁶⁷ Shock cooling meaning the process gases are cooled very rapidly from about 1400°C to 70°C.

¹⁶⁸ Henriksson, Hans. (2002, July 5). Purchase of EEE waste, Boliden. Telephone interview

Table 4-6 shows the emissions from the Kaldo furnace, when run on electronic scrap, in 2001. As can be seen in the table, 0.536 tons of Pb were emitted to the air.

Table 4-6. Emissions from the Kaldo furnace in 2001, when used for processing EEE waste. The figures are based on a total operating time of 5 113 hours. tpa = tons per annum, gpa = grams per annum, TCDD eqv. Eadon = the sum of dibenzodioxins and furans according to the Eadon-model (each chemical within the group of dioxins and furans has been assigned a factor which describes the toxicity of the species relative to that of 2,3,7,8-tetrachlorodibenzodioxin (2,3,7,8-TCDD), which is the most toxic chemical of this group).

Dust (tpa)	Cu (tpa)	Pb (tpa)	Zn (tpa)	Cd (tpa)	As (tpa)	Hg (tpa)	NO _x (tpa)	F (tpa)	Cl (tpa)	TCDD eqv. Eadon (gpa)
2.098	0.019	0.536	0.098	0.002	0.002	0.008	17	0.03	0.10	0.056

Source: Boliden 2002a.

4.4.3 Conversion

The black copper from the Kaldo furnace is fed into the copper converter and mixed with processed and smelted copper ore, so-called copper matte (pre-treated in other furnaces on the plant). Air enriched with oxygen is blown over the melt to purify the copper by oxidising iron and sulphur. Silicate is also added to the converter as a slag-former. The process temperature is about 1 200°C. The conversion process is an exothermic process, due to the oxidation processes involved, and thus, generates enough heat to run on its own.

An upper layer of slag, containing predominantly iron and zinc and a lower layer of so-called blister copper or white copper are produced. The slag is removed and is further treated and purified to give the by-products iron sand and zinc clinkers.¹⁶⁹ The slag is thus fed back into an electric furnace in the copper process line. Thereafter, the slag from the electric furnace, which contains predominantly iron and zinc, is further treated in a fuming plant to extract zinc clinkers and iron sand (see Figure 4-4).

The process gases from the converter are treated in several steps and most of the metals are captured as dust. This dust is then either sent to other smelting plants in England or is temporarily stored onsite. Currently, approximately 24% of the dust is exported to England, while the remaining 76% is temporary stored, onsite.^{170, 171} In 2001, a total 1848 tons of dust from the whole plant, not specifically related to the processing of electronic scrap, was exported to England.¹⁷² The future of the process dust, stored onsite, is being evaluated to develop a plan for final treatment/deposition.¹⁷³ One reason, according to Henriksson, that some of the filter dust is stored onsite, is the complicated regulations set on waste that is exported and imported. Boliden has to comply with an expensive notification procedure, which turns the possible income on the dust into costs for the company.¹⁷⁴

¹⁶⁹ Christensen, F., Jørgensen, T. & Nielsen, I. (2000). *Environmental and technical characteristics of conductive adhesives versus soldering*, pp. 25-27.

¹⁷⁰ Borell, Michael. (2002, September 16). Environmental Manager, Boliden. Telephone interview.

¹⁷¹ Boliden. (2002a). Miljörapport 2001 Rönnskärsverken och Rönnskärs hamn. Compulsory Environmental Report, produced for the inspection authorities.

¹⁷² Boliden. (2002a). Miljörapport 2001 Rönnskärsverken och Rönnskärs hamn. Compulsory Environmental Report, produced for the inspection authorities.

¹⁷³ Boliden. (2002a). Miljörapport 2001 Rönnskärsverken och Rönnskärs hamn. Compulsory Environmental Report, produced for the inspection authorities.

¹⁷⁴ Henriksson, Hans. (2002, September 13). Purchase of EEE waste, Boliden. Telephone interview.

With regard to the emission of the metals addressed in this study, it should be mentioned that Boliden's copper smelter mainly processes copper concentrate from copper ore. This concentrate, after it has been smelted, is mixed with black copper from the Kaldo furnace in the copper converter. Thus, the concentrations of the metals in the copper concentrate have a big impact on the emission levels. In Table 4-7 a typical composition of the copper concentrate used in Boliden is displayed. As can be seen, the concentrate contains all the metals except tin, which predominantly comes from EEE waste. Thus, when addressing emissions from the converters and from the fuming plant, other raw materials which contain the same metals, are mixed with the EEE waste, which makes it complicated to trace the metals originally contained in the EEE waste. However, in the case of tin, almost all comes from electronic scrap.

Table 4-7. Typical composition of the copper concentrate processed in Boliden's smelter. This concentrate, after it has been smelted, is mixed with smelted EEE waste in the converter and consequently the metals looked upon in this thesis, with exception for tin, will not only come from the EEE waste but also from the copper concentrates.

Main components	Other metals	Impurities	Other elements
Cu 27%	Au 0.002%	Pb 1-3%	SiO ₂ 5%
Fe 25%	Ag 0.05%	As 0.1-0.3%	Al ₂ O ₃ 2%
S 30%	Zn 1-5%	Cd 0.02%	MgO 2%
		Hg 0.0001-0.01%	
		Sb 0.2%	
		Bi 0.05%	

Source: Boliden 2002a.

4.4.4 Anode casting

The oxidised blister copper (98% copper) coming out of the converter is injected with liquid ammonia as it is being poured out of the converter to be cast into copper anodes. The purpose of the liquid ammonia is to deoxidise the blister copper. The formed copper anodes contain about 99% copper and 0.5% precious metals.¹⁷⁵

4.4.5 Electrolysis

The copper anodes are refined in an electrolysis treatment, using sulphuric acid and copper sulphate as the electrolyte. The anode plates are placed in electrolyte tanks, with a cathode sheet put in-between every copper anode. The cathodes are made of stainless steel. During the process, a current of about 20 000 amperes, direct current, is used in order for the copper to be transferred to the cathodes. The precious metals and impurities that remain on the anodes, settle as anode slime. This slime is then pumped to a precious metals plant for further refining. The end product of the electrolytic refinery is 99.99% pure copper cathodes, which are ready to be sold on the market.¹⁷⁶

4.4.6 Precious Metal Refinery

In the precious metal refinery, gold, silver, platinum, palladium and selenium are recovered. Figure 4-9) displays the precious metal refinery process at Noranda's copper smelter. During the process, the anode slime from the electrolysis process is firstly pressure leached. From the solvent copper telluride

¹⁷⁵ Henriksson, Hans. (2002, July 5). Purchase of EEE waste, Boliden. Telephone interview

¹⁷⁶ Berglund, Christina. (2001). End of Life Treatment Requirements of Materials Content for Electronics. pp. 15.

and nickel sulphate are recovered in copper sulphate and tellurium plants. The leach residue is then dried and after the addition of fluxes, smelted in a precious metal furnace. During smelting, selenium is recovered as one fraction. The remaining, primarily silver, is cast into silver anodes. At a subsequent, high intensity electrolytic refining process, high purity silver and gold slime are formed. The gold slime is then leached and high purity gold as well as palladium/platinum sludges are precipitated.^{177, 178}

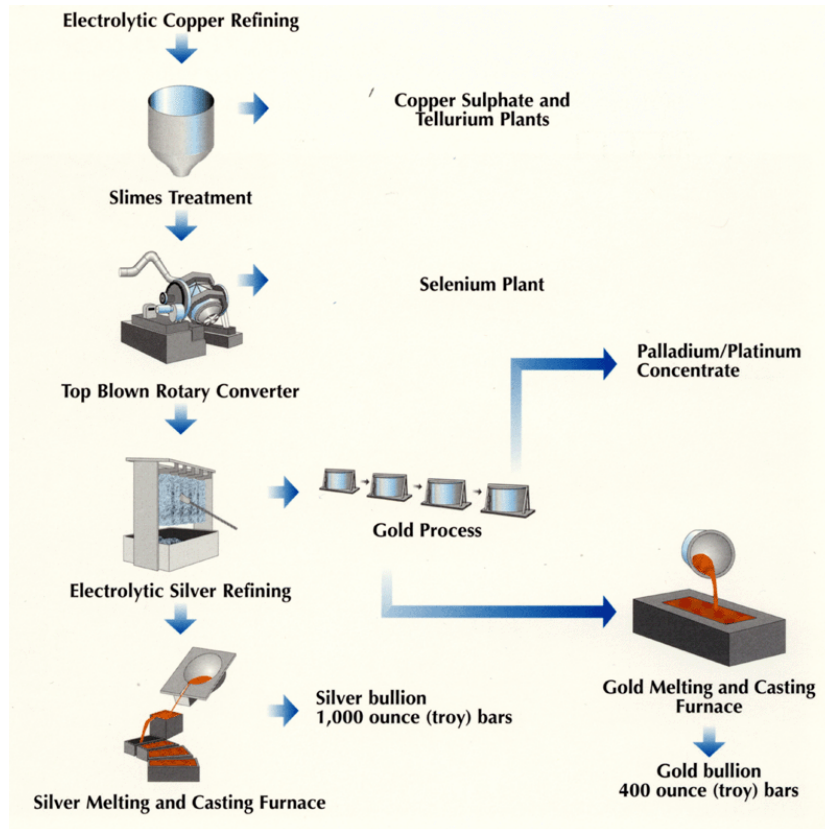

Figure 4-9. The precious metal refinery process at Noranda. The slime from the electrolytic copper refinery is fed into the precious metal refinery process to extract silver, gold, palladium and platinum. Copper telluride and nickel sulphate, recovered in the copper sulphate and tellurium plants, and selenium are also recovered as by-products. Source: Noranda Metallurgy Inc.

4.5 The Fate of Tin-Lead and Lead-Free Solders in the Metal Recovery Process

As described earlier in this chapter, several steps are involved in the metals recovery process from PCBs. It is therefore, important to understand the fate of the different metals in the whole process for an understanding of possible environmental impacts. In the smelting processes used by Boliden and Noranda, copper and silver are refined, while lead, tin and bismuth come into the process as impurities, which are “boiled” away. For a summary of the fate of the metals in the process see Figure 4.10.

¹⁷⁷ Boliden. (2000). New Rönnskär. Company Booklet.

¹⁷⁸ Noranda Metallurgy Inc. (?). Noranda Recycling.

The information contained in this section is predominantly based upon information received during a study visit to Boliden's copper smelter.

Lead

In the smelting process, approximately 75-80% of the lead from lead solders, is transported with the black copper to the copper converter. Fifteen to twenty percent of the lead is "boiled" away and follows the process gases, while only a small fraction, about 5%, is captured in the slag.

Most of the lead contained in the slag, which is further processed in a flotation process to recover the remaining precious metals and copper, is in the end deposited in tailings impoundment areas. Thus, this lead, which constitutes approximately 5% of the lead fed into the Kaldo furnace, is lost in the smelting process to tailings in the mining areas.

In the converter, the lead either follows the process gases or is deposited in the slag. The lead contained in the slag, which is fed back into the electric furnace in the copper process line, follows the slag formed in the electric furnace and thus, can be treated in the fuming plant (see Figure 4-4). In the fuming plant, most of the lead follows the process gases. Consequently, in the end almost all of the lead fed into the converter directly or indirectly ends up in the process gases.

In total, about 95% of the lead fed into the Kaldo furnace is "boiled" away and follows the process gases. Most of this will then be captured in the gas cleaning devices, as filter dust. This dust is then sent for further refining in England or is temporarily stored on-site. During an interview with Borell, the Environmental Manager at Boliden, it was expressed that approximately 25% of the total amounts of dust trapped at the different gas cleaning steps was sent to England for further refining while 75% was temporarily stored onsite, until further investigations of final disposal treatment are completed.¹⁷⁹ In 2001, 7 800 tons of filter dust was generated, in total for the whole processing plant, of which 1 848 tons, or about 24%, was sent to England for further refining.¹⁸⁰

The next question to ask is, how much of the lead that follows the process gases are not trapped in the filters as filter dust? During an interview with Lehner, the Manager Research and Development at Boliden, it was stated that approximately 99.9% of the lead that follows the process gases are captured in the gas cleaning devices.¹⁸¹ Due to the complexity of Boliden's smelting process and the various input into the different process steps, it is hard based upon on the information collected in this research, to verify the accuracy of this figure. However, in a try to validate the figure, the author made estimations of how much the dust expelled into the air constitutes of the total amount of filter dust entrapped annually. In the compulsory Environmental Report, produced for the inspection authorities in Sweden, for 2001, it was presented that, in total, 56.8 tons of process dust were expelled as air emissions.¹⁸² Based upon this figure, the author estimated that 99.2% of the dust in the process gases is entrapped, as filter dust. Thus, the author concludes that of the approximately 95% of lead, which follow the process gases, somewhere between 99.2 to 99.9% is collected in the gas cleaning devices.

Tin

About 90% of the tin fed into the Kaldo furnace is transferred to the copper converter, while most of the remaining tin is expelled in the process gases. In the converter, the tin will follow the process gases

¹⁷⁹ Borell, Michael. (2002, September 16). Environmental Manager, Boliden. Telephone interview.

¹⁸⁰ Boliden. (2002a). Miljörapport 2001 Rönnskärsverken och Rönnskärs hamn. Compulsory Environmental Report, produced for the inspection authorities.

¹⁸¹ Lehner, Theo. (2002, September 16). Manager Research and Development, Boliden. Telephone interview.

¹⁸² Boliden. (2002a). Miljörapport 2001 Rönnskärsverken och Rönnskärs hamn. Compulsory Environmental Report, produced for the inspection authorities.

in the same pathway as lead. Thus, in the end, almost all of the tin is expelled in the process gases. Most of this tin is captured as filter dust, which is either sent to England, approximately 24%, for further refining or is temporarily stored, onsite. Based upon the same findings and assumptions made for lead, approximately all of the tin from the solders will follow the process gases. In the process gases, somewhere between 99.2 to 99.9% of the tin is entrapped as filter dust in the gas cleaning devices.

Copper and Silver

In the copper smelting process more than 95% of the copper fed into the process will be recovered as copper cathodes. The recovery rate of silver is also estimated to be above 95%. Thus, no other significant pathways for copper and silver are identified.

Bismuth

Almost 100% of the bismuth coming into the Kaldo furnace is transported with the black copper to the converter. In the converter, most of the bismuth follows the process gases and will be trapped in gas cleaning devices, in the same proportions as for lead and tin. The remaining bismuth, less than 20%, is captured in the melted copper and will finally end up in the copper cathodes.

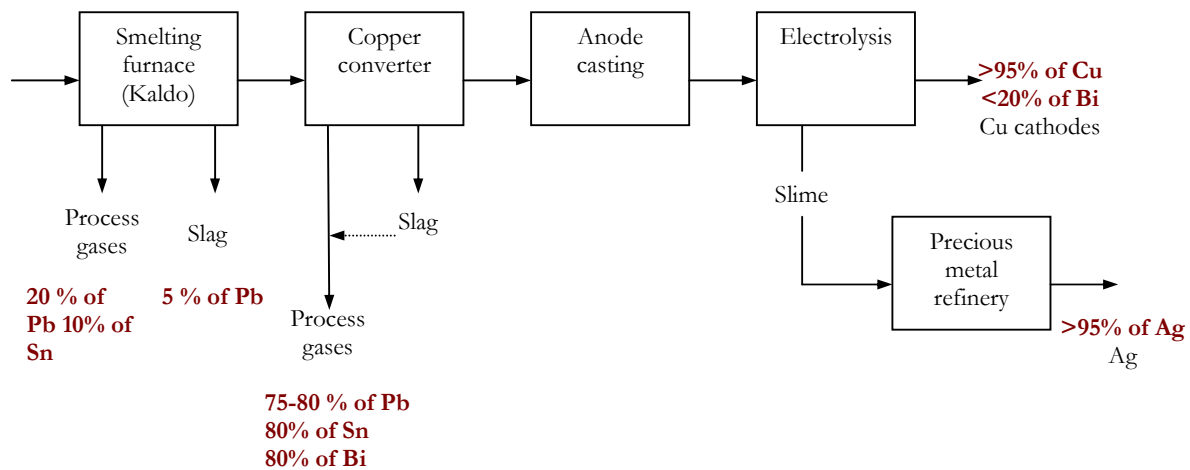
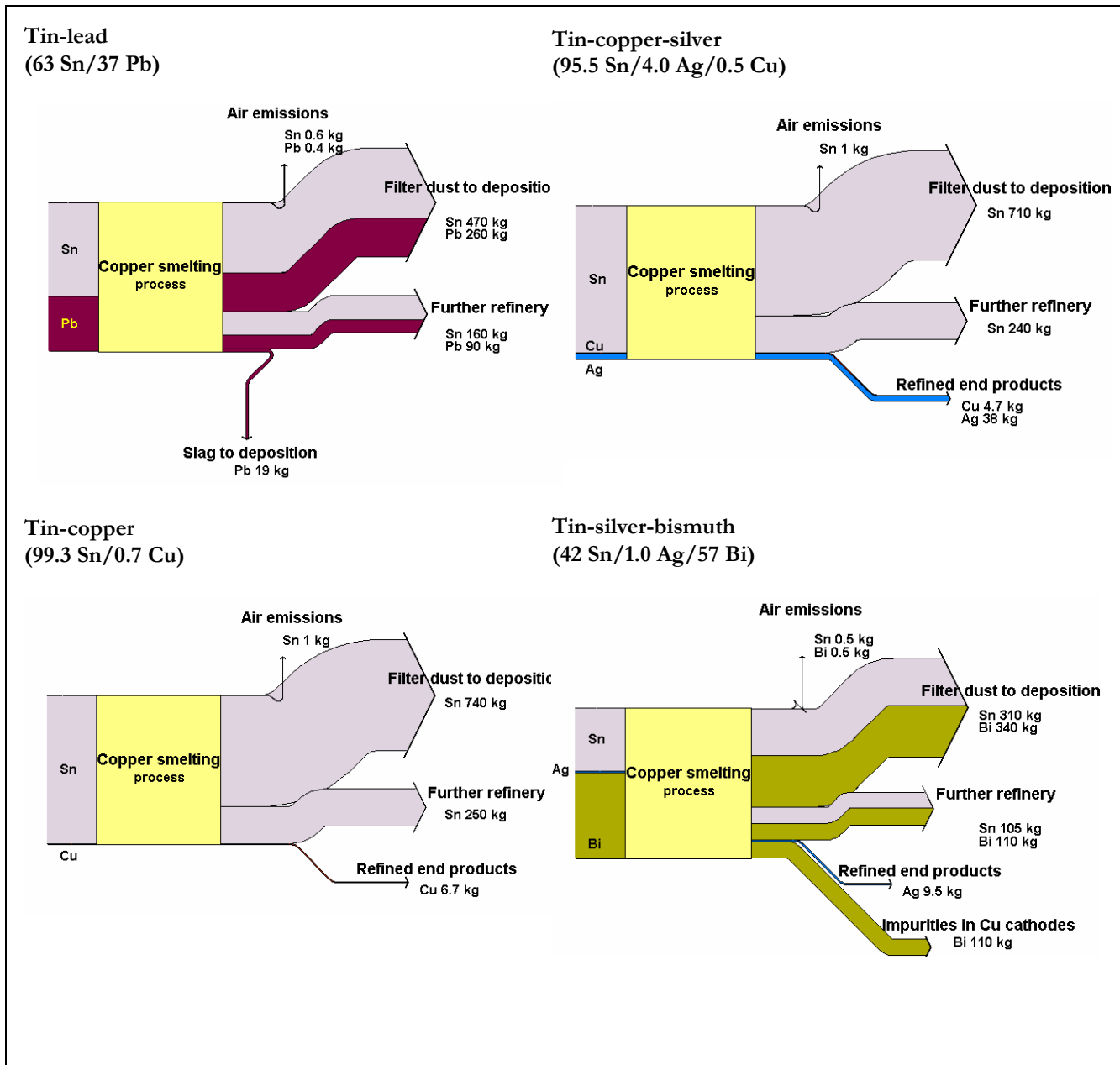

Figure 4-10. The fate of lead, tin, copper, silver and bismuth in Boliden's metal recovery process in Rönnskär, Sweden. The process gases from the copper converter are fed back into an electric furnace, which processes secondary copper materials. The lead, tin and bismuth contained in the slag will in the electric furnace be expelled in the slag and transported to a fuming plant, where zinc and iron are primarily processed. In the fuming plant, most of the lead, tin and bismuth follows the process gases and will subsequently be trapped in gas cleaning devices. Consequently, in the copper converter, the lead, tin and bismuth are directly or indirectly, via the electric furnace and the fuming plant, expelled in the process gases and thereafter collected as filter dust in the gas cleaning devices.

Tin-lead and lead-free solders

Based upon the findings of the fate of the metals in the smelting process, described previously in this section, a summary of the fate of tin-lead and the lead-free solders, calculated per ton solder, is presented in Box 4-1 and Box 4-2.

Box 4-1. Fate of tin-lead, tin-copper, tin-silver-copper and tin-silver-bismuth in the smelting process. The calculations are based upon 1 ton of solder. For copper and silver, 95% of what is fed into the process is estimated to be recovered as final end products. The efficiency of the flue gas cleaning system is estimated to be 99.9%.



Box 4-2. Fate of the tin-silver-copper-bismuth alloy in the smelting process. The calculations are based upon 1 ton of solder. For copper and silver, 95% of what is fed into the process is estimated to be recovered as final end products. The efficiency of the flue gas cleaning system is estimated to be 99.9%.

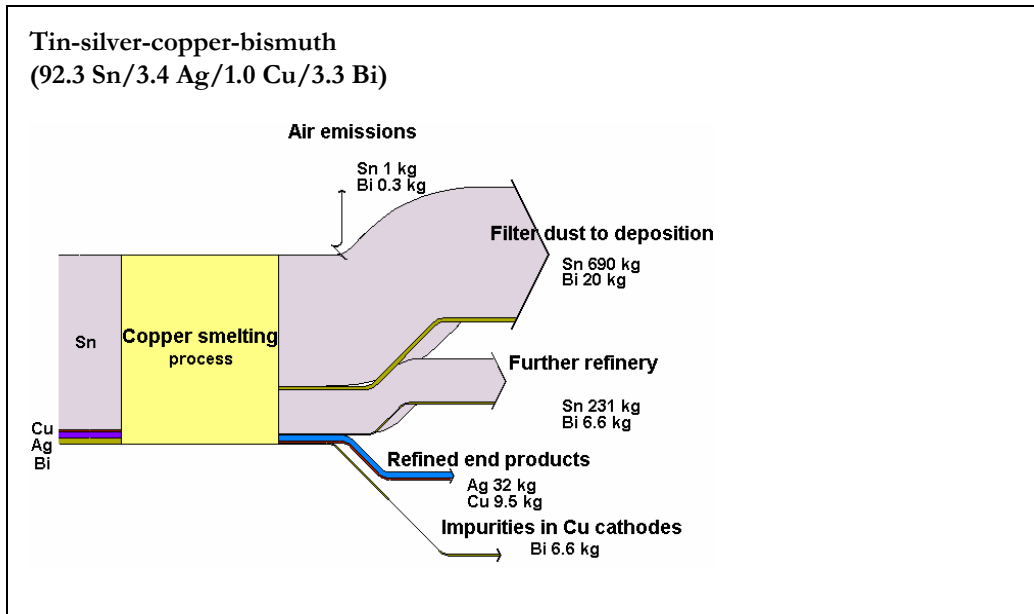

4.6 Solder Recycling at the Manufacturing and Application Steps

Solder recycling also takes place at an earlier lifecycle stage of solders. Although, this type of recycling falls somewhat outside the scope of this thesis, it is still worth mentioning.

Solder recycling at the manufacturing and application steps, as referred to as solder recycling in Figure 2-2, involves the recycling of leftover and oxidised solder (thus no EEE waste is processed), the latter more known as dross, from the two processing steps. In this type of recycling, a lead-based recycling process is used, principally the same process as for recycling lead-acid batteries. Firstly, the solder and dross is smelted in a furnace to obtain a metallic lead which is further refined, i.e. from other impurity metals, by thermal and electrolytic refining. In the thermal refining process open kettles are heated and impurities, e.g. copper, are skimmed off at the top. Thereafter, the lead goes through an electrolytic refining step to produce lead cathodes, which can go back into manufacturing production of new solders. The slime from the electrolytic refining is further treated to recover single metals.¹⁸³

¹⁸³ Pistoia, G., Wiaux, J.-P. & Wolsky, S.P. (2001). *Used Battery Collection and Recycling*. Industrial Chemistry Library, Volume 10. Amsterdam: Elsevier Science B.V. pp. 256-260.

5. Analysis

In general, it can be said that in the recycling systems, in operation today for end-of-life EEE, there is no direct focus on recycling of tin-lead solders. Instead, it is the economic value of precious metals contained in the PCBs that drives the recycling system for PCBs. This does, however, not mean that none of the tin or lead contained in the solders is recycled. Although, Boliden's copper smelter cannot, on its own, recycle the incoming tin or lead from solders, indirectly, through other smelters, which have the proper refining techniques, these metals can be recycled. Approximately 24% of the tin and lead that is captured in the flue-gas filters at Boliden is today sent to England for further treatment, while the remaining 76% is temporarily stored onsite until further assessments of the final disposal treatment of this dust have been made. Consequently, although one fraction of the metals entrapped in filters is recycled, most of the metals are today lost to some sort of disposal treatment, as most of the filter dust is stored onsite awaiting final disposal treatment. In the recycling process run by Umicore, direct recovery pathways for tin and lead are in operation. However, during the research, no information about the details of Umicore's process was found, thus, most of the findings in this thesis are based upon the metal recovery processes run by Boliden

5.1 What Quantities of Solders are Treated in the Recycling Systems in Operation Today?

The next important question to ask, to be able to assess the possible implications of a substitution of lead, is how much solders is being treated in the recycling systems currently in operation?

The data referred to in Sections 4.1.1 and 4.1.2, of this thesis, are summarised in Table 5-1. As can be seen in the table, the amounts of EEE waste generated and separately collected for recycling vary extensively in different countries. For the amount generated, part of the explanation for the differences lies in that countries define EEE waste differently, i.e. the figure for the U.S., of 7.5 kg/capita per year, includes consumer products while the EU figure of 19.8 kg/capita per year includes consumer products and large and small household appliances. However, the figure of 8.3 kg/capita per year in the Netherlands includes the same product types as for the EU, and thus, there are some other, not clarified differences.

Table 5-1. Amount of EEE waste generated and separately collected for recycling in different countries. For EU and Portugal where no data on how much is currently being collected have been found, collection targets set by upcoming legislation are presented. In EU, the target of 6 kg/capita per year was established by the proposed WEEE directive. In Portugal, the collection target of 2 kg/capita per year has to be fulfilled by December 31, 2003. Data gaps means that the information is missing/not applicable (collection targets) or that there was no information found on it during the research.

	Generation (kg/capita per year)	Collection target (kg/capita per year)	Collection (kg/capita per year)	Collection rate (%)
The Netherlands	8.3	-	4	48
Norway	29.2	-	13.16	45
Sweden	22.4	-	10	45
Switzerland	15,3 ¹	-	-	-
The U.S.	7.5 ²	-	0.69	9
EU	19.8	6	-	30 ³
Portugal	-	2 ⁴	-	-

¹ Source: Swiss Agency for the Environment, Forests and Landscape 2002. Population in Switzerland estimated to 7 170 000 people.

² The U.S. population is estimated to be 281 421 906 in 2000.

³ Collection rate for EU is based on the collection target of 6 kg/capita per year, set by the WEEE directive.

⁴ Source: CECED 2002.

Based upon current statistics available for EEE waste, it is hard to estimate a generic recycling figure for EEE. In October or November 2002, the European Topic Centre on Waste and Material Flows will present a report, which includes estimations of the fate of EEE waste generated within the EU that will shed some light over current waste management of EEE. However, at this point, the recycling rates for EEE waste generated within the EU can only be estimated. Based upon the collection target of 6 kg/capita per year (presently equivalent to a collection rate of 30%) set by the WEEE directive, the author believes that current average collection rate within the EU is most likely less than this. At the same time, a collection rate of 9 %, which is the estimated rate in the U.S. can, according to the author, be seen as a lower limit. Several of the EU Members have today implemented EPR legislations that, most likely, make the EU average collection rate higher than the U.S. rate. Based upon the best data currently available, the author estimates that the current average collection rate in the EU of EEE wastes is approximately 15% of what is actually generated per year.

In 1995, the Council of Nordic Ministers estimated that PCBs account for 3.1 % of the total amount EEE waste generated.¹⁸⁴ Based upon this estimation and the author's assumption that 15% of the EEE waste is separately collected, the fate of the PCBs generated in EU is estimated as displayed in Figure 5-1. Based upon the intrinsic value of PCBs, a recovery rate (of the amount collected) of approximately 100% is assumed. Consequently, 30 000 to 40 000 tons of PCBs, generated in EU, are estimated to be destined for recycling activities, annually.

As described in Section 4.2, the dismantlers normally divide PCBs into low and high value fractions, depending on the content of precious metals. The PRO in Norway, El-Retur, reported, in 2001, that of the PCBs collected for electronic products and white goods, a 1:8 relationship between high and low value fractions was achieved.¹⁸⁵ However, how representative this distribution is for all PCBs collected in the EU is unknown.

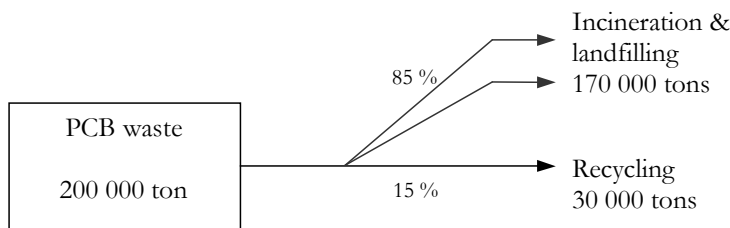

Figure 5-1. Estimated fate of PCBs generated in EU.

The four large copper smelters that process EEE waste, collectively treat approximately 100 000 tons per year. Of this, the author, based upon an interview with Henriksson at Boliden, estimates that PCB waste accounts for 50% or 50 000 tons.¹⁸⁶ This corresponds well with the figure reported by the

¹⁸⁴ Taberman, S-O., Carlsson, B., Erichsen, H., Legarth, J., & Gregersen, J. (1995). *Environmental Consequences of Incineration and Landfilling of Waste from Electr(on)ic Equipment*. p. 29.

¹⁸⁵ El-Retur. (2001). *Resultater og Statistikk* [Results and Statistics] <http://www.elretur.no/ElRetur/statisticER.do> [2002, 13 September].

¹⁸⁶ Henriksson (2002) who works at the purchase department of Boliden, Rönnskär, estimated, during an interview, that PCBs accounts for 50-60% of the incoming EEE waste at Boliden.

Swedish EPA from 1995, where it was stated that Boliden's copper smelter received 12 000 tons of electronic scrap of which 6 000 tons were PCBs.¹⁸⁷ Based upon the assumption that 30 000 tons of PCBs within the EU are destined for recycling, the PCB waste generated within the EU accounts for approximately 60% of the total amount of PCBs treated at the copper smelters.

Solder constitutes about 2 % of the PCBs.¹⁸⁸ Based upon the assumption that the copper smelters together process 50 000 tons of PCBs per annum, some 1 000 tons of solder, worldwide, are assumed to be destined for the PCB recycling activities, annually. The figure for how much solder, generated in the EU, is being treated in the recycling systems, is estimated, based upon the calculations above, to be 60% of the total amount, equivalent to 600 tons of solder annually.

5.2 The Recycling System for EEE waste

5.2.1 Organisation

During recent years, separate collection systems for the recycling of EEE waste have been established in several countries. The recycling systems are set-up so that the EEE waste is firstly collected and transported to dismantling facilities, where a manual separation of the waste into different fractions takes place. The manual sorting and dismantling is, in most cases, necessary in order to remove the hazardous substances before the other materials can be recycled or dealt with in a safe and suitable way.¹⁸⁹ The fractions containing PCB, low and high-grade fractions, are thereafter, sold to copper smelters, which feed the material into their process to predominantly recover precious metals and copper.

The establishment of recycling systems are in most cases driven by legislative pressure or economics. During the last years several EPR legislations have been enacted in Europe, which put the financial and physical responsibility on the producers to recycle and recover the EEE waste. The producers have to meet certain recovery targets and assure that minimum separation requirements, for the EEE waste separately collected, are fulfilled. Most of the municipalities are responsible for the establishment and operation of collection systems for the EEE waste, while the producers are responsible for the subsequent management steps.

There are currently four large copper smelters on the global market that process PCBs, i.e. Boliden (Rönnskär, Sweden), Noranda (Rouyn-Noranda, Quebec, Canada), Umicore (Hoboken, Belgium) and Norddeutsche Affinerie (Hamburg, Germany). The PCBs are fed into the regular smelting processes to refine the precious metals and copper contained in the material. The driving force is the economic value of the precious metals and copper recovered.

Technical Aspects

When PCBs are processed in the copper smelters, tin-lead solders are predominantly “boiled” away in the process to refine copper and precious metals. Although, tin and lead are not refined in the smelting process described in this thesis, most of the materials, including tin and lead, in the process gases, are captured in various gas cleaning devices and can be re-processed, by other smelters, into useable metals. However, during the research it was found that as much as 76% of the captured dust is not sent for further refining, but is instead awaiting some sort of final disposal treatment to be decided in the future.

¹⁸⁷ Swedish EPA. (1995). *Electronic and Electrical Equipment – The Basis for Producer Responsibility*. p. 34.

¹⁸⁸ Assumption made by the author based upon that PCBs contain about 1% tin and 1.5% lead (see Table 4-5).

¹⁸⁹ Swedish EPA. (1995). *Electronic and Electrical Equipment – The Basis for Producer Responsibility*. Summary and Conclusions.

5.2.2 Environmental Aspects

The Environment

Lead is highly toxic to both humans and the environment. Its low melting point makes it a relatively volatile metal. Thus, when treated in any kind of combustion processes large amounts of the lead are volatilised, which can cause problematic air emissions if not treated properly.¹⁹⁰

In the collection and dismantling processes, no heat is added in the process to separate the PCBs and consequently lead emission risks should be low. According to Axelsson, Market Engineer, at Arvamet, a shredding/processing facility in Sweden, there seems to be no significant environmental impacts associated with the leaded-solders in the dismantling process.¹⁹¹

In the copper smelters most of the lead will be trapped in the process gas dust filters. However, some lead will escape to the air, as air emissions. During interviews with representatives from Boliden, it was stated that approximately 99.9% of the lead in the process gases is collected in the flue gas cleaning devices, as filter dust. The same figure, calculated by the author, was 99.2%.

The fate of lead that is trapped in the filter dust very much depends on the economic situation. If good economic incentives are present, the dust will be further processed to recover the metals contained. However, at the moment, significant amounts of the dust produced at Boliden are stored onsite. In this way, the smelter could actually build up big costs that it has to deal with sometime in the future.

Worker's Health

EEE waste contains metallic and organic dust, which can cause problems for the workers when the scraped products are dismantled manually. When the EEE are opened and separated into different fractions, the dust contain in old EEE can be released into the surrounding environment and can cause worker's health problems. However, during an interview with Axelsson, Market Engineer, at Arvamet, it was expressed that, in principal, all of the lead used in solders is retained in the solders and thus, leaded solders will most likely not lead to any significant problems related to the dust already contained in old EEE. However, during the study, it was also revealed that at the shredding step, some concern for worker's health, related to the metallic dust that is generated here, has been expressed. Thus, it is of the author's opinion that, at the shredding step, it is possible that dust particles, containing lead from the solders, can cause problems to the workers if the right filter treatments and precautions are not taken.

The workers at the copper smelter may be exposed to lead emissions. The lead exposure is therefore, measured continually. Figure 5-2 shows the blood lead levels of the workers at Boliden, Rönnskär during the period from 1950 to 2001. As can be seen in the figure, the blood lead levels have decreased very much since the first measures were taken and today's levels are far below the Swedish norm for lead workers. Additionally it shall be said that Boliden besides processing electronic scrap, containing lead, also processes large amounts of lead ore. In 2001, 31 300 tons of lead were produced and consequently, most of the lead that the workers are exposed to, although the lead exposures still are small, comes from the lead ore processing.¹⁹² Thus, the author concludes that the risks with lead exposure from electronic solder to the workers at the copper smelters seem to be small.

¹⁹⁰ Ayres, R., Ayres, L. & Råde, I. (2002). *The Life Cycle of Copper, its Co-Products and By-Products*. p 63.

¹⁹¹ Axelsson, Anders. (2002, September 2). Market Engineer, Arvamet. Personal interview.

¹⁹² Boliden. (2002a). Miljörapport 2001 Rönnskärsverken och Rönnskärs hamn. Compulsory Environmental Report, produced for the inspection authorities.

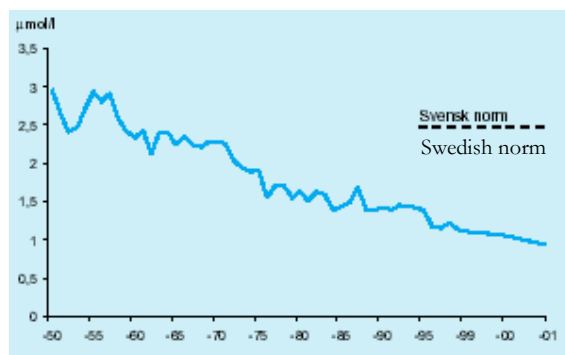

Figure 5-2. Average blood lead level (measured in μ mol Pb/litre) for the workers at Boliden, during the period from 1950 to 2000. Source: Boliden 2001.

Energy Consumption

Both the Kaldo and the conversion consume little external energy/fuel when run. In the Kaldo process, energy from the plastic is used to smelt the EEE waste, while the converter process is an exothermic process in itself, which thus generates enough heat to run on its own. However, during the study no specific data for the energy consumption in these process steps, verifying what is said above, was able to be collected.

Boliden generates electricity from the process gases by using the waste heat to produce high-pressure steam. It also supplies energy for the district heating to the nearby Skellefteå township.

5.3 Possible Implications of a Substitution of Lead in Solders

This part of the analysis is based upon a comparison of the new lead-free alternatives with the eutectic tin-lead solder. The analysis is a comparison of the possible impacts of the consequences of the replacement of lead-tin solder with lead-free alternatives as well as if no such substitution occurs.

5.3.1 Environmental Implications

The Environment

In general, it can be concluded that lead is the most toxic metal of the five metals looked upon in this thesis research. Lead is known to be highly toxic to both humans and the environment, while tin and silver are toxic to the aquatic environment. The ecotoxicity of copper is less known and needs to be further investigated. However, most questions still remain about the toxicity and ecotoxicity of bismuth. Some argue that bismuth is “the new ecologically green metal”, considering that it is non-toxic or at least is the least toxic metal of all known today.¹⁹³ Others are more careful and say that bismuth might in the near future be listed as a hazardous element and thus, should be avoided.¹⁹⁴

During dismantling, where no heat is added during the process and consequently none of the solder is lost, there seems to be no significant environmental impacts related to the currently used tin-lead solder or any of the lead-free alternatives. Thus, during the dismantling process, the type of solder used does not seem to have any significant environmental impacts.

¹⁹³ Rohr, O. (2002). Bismuth – the new ecologically green metal for modern lubricating engineering.

¹⁹⁴ Fuchs, Stefan-Georg. (2002, July 5). Umicore Precious Metals. *Re: Tin/lead solders vs. Alternatives*. E-mail to Ulrika Kindsjö.

When the EEE waste is treated in the copper smelters most of the lead, tin and bismuth contained in the material is “boiled” away and is collected as filter dust in the gas cleaning devices, while the copper and silver are refined as end products. Thus, from a resource perspective, it would be beneficial to switch to a solder that contains more copper and silver, since these metals, in contrast to lead, tin and bismuth, are recovered in the smelting process, described in this thesis. However, when comparing the flow diagrams in Box 4-1 and Box 4-2, for the lead-free alternatives, addressed in this thesis, with the tin-lead solder, it can be concluded that the differences in the total amounts of metals lost to deposition via filter dust is not that different. In general, the lead-free alternatives contain more tin or tin and bismuth, in the case of the tin-silver-bismuth alloy, which will predominantly follow the same pathway as lead. Consequently, the amounts of raw materials lost in the process, to deposition, will be almost the same. However, once more it is worth pointing out that lead is the most toxic of these metals addressed and thus extra cautions about lead emissions should be taken.

As can be seen in Figure 5-3, the melting points, which is one condition for that the metals can be expelled in the process gases, are much lower for tin (232°C), bismuth (272°C) and lead (327.5°C) than for silver (961°C) and copper (1 085°C).¹⁹⁵ However, other factors, e.g. the composition of the smelt, are also important for the distribution of the metals. During the research it was concluded that most of the tin, lead and bismuth contained in the electronic scrap that is fed into the smelting process, will be “boiled” away and subsequently be collected as dust in the flue gas cleaning devices. No difference in the efficiency of the gas cleaning devices for trapping these metals were found.

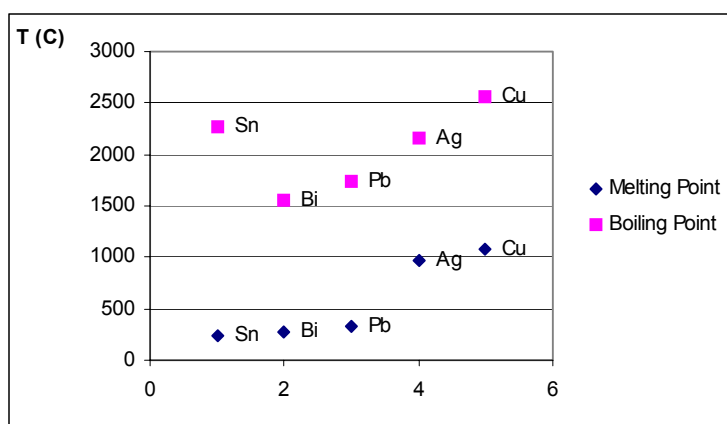

Figure 5-3. Melting and boiling points for tin (232°C), bismuth (272°C), lead (327.5°C), silver (961°C) and copper (1 085°C). Source: Environmental Chemistry 2002.

Worker’s Health

In the shredding process, some concerns about lead emissions have been raised¹⁹⁶ and thus, it might be beneficial to substitute tin-lead solders with any of the other alloys.

In the smelting process, good worker’s health precautions are taken today and therefore, there seems to be no significant health problems related to the lead contained in the solder.¹⁹⁷

Energy Consumption

¹⁹⁵ Environmental Chemistry. (2002). *Periodic Table of Elements*. <http://environmentalchemistry.com/yogi/periodic/index.html> [2002, 20 August].

¹⁹⁶ Axelsson, Anders. (2002, September 2). Market Engineer, Arvamet. Personal interview.

¹⁹⁷ Lehner, Theo. (2002, September 2). Manager Research and Development, Boliden. Personal interview.

When EEE waste is processed in the smelting furnace, the process is run on the energy content of the plastic materials contained in the EEE waste. In the next step, in the copper converter, the process is exothermic, due to the oxidation processes involved, and enough energy is generated to run the process on its own. Thus, the energy consumption in the initial smelting processes, where most of the solder is treated before it is “boiled” away, is very small. Consequently, a substitution from tin-lead solders to any of the other lead-free alternatives will most likely have no significant impacts on the energy consumption during the recycling of the EEE waste.

5.3.2 Technical Implications

The copper smelters produce copper cathodes, of a copper purity of 99.998%. One of the big problems in the process today is that some of the bismuth, coming into the process follows the copper smelt and contaminates the cathodes.¹⁹⁸ In case the bismuth is derived from electronic scrap, as much as 20% of the bismuth contained in the PCBs can follow the copper and thus end up in the copper cathodes. Consequently, the problem today is that some bismuth will be contained in the copper and the only way to control that the amounts are not too high is to control how much Bi is fed into the process in the first step. The problem with bismuth holds true for the copper smelting processes run by Boliden, Noranda and Norddeutsche Affinerie. However, the Umicore Precious Metal’s smelter uses another process, which actually can separate bismuth from the other elements. But according to Fuchs, at Umicore, bismuth is still more costly to recover than its intrinsic value can justify and should be avoided.¹⁹⁹ Umicore leaders therefore, say that in case the amounts of bismuth will increase in PCBs, they will be able to adapt to the change by penalising their suppliers for the content of bismuth.²⁰⁰ The other copper smelters might also have a possibility to adapt to higher concentrations of bismuth by adding a completely new separation step to their current processes. However, this will most likely be very costly and the right economic incentives must be present to make sure that the smelters will actually continue to process the EEE waste.²⁰¹

Tin may also cause problems. Tin is not refined in Boliden’s process and, as stated earlier in this thesis, most of it follows the process gases in the converter and is collected as filter dust in the treatment step. This dust is then either deposited onsite or is further processed at other smelters that can refine the metals contained in the dust, and this is where the problems with tin might occur.²⁰² These smelters use a lead refining process, which has problems with too high a tin content. The same also holds true for the smelting process used by Umicore. Fuchs states that even though tin is considered a disturbing element, the current yields of tin in solders are so low that there is no substantial concern about the presence of tin today.²⁰³ However, to get a better understanding of the possible, if any, technical implications of tin in solders on the recycling system, the author recommends that in depth investigations of the processes run by the smelters that process these filter dusts should be conducted. Due to limited information available about these smelters and time constraints, it was not feasible to include assessment in this thesis.

In the future, where the amount of EEE waste separately collected will most likely increase due to upcoming recycling legislations, new recycling processes to specifically recover the solders contained in

¹⁹⁸ Derek, Frey. (2002, July 9). Professor at the materials science and metallurgy department, at the University of Cambridge (UK). *Re: Recycling of solder*. E-mail to Ulrika Kindsjö.

¹⁹⁹ Fuchs, Stefan-Georg. (2002, July 5). Umicore Precious Metals. *Re: Tin/lead solders vs. Alternatives*. E-mail to Ulrika Kindsjö.

²⁰⁰ Wesseldijk, Quierine. (2002, September 6). Manager Raw Materials Supply – Recycling, Umicore Precious Metals. *Re: Smelting process*.

²⁰¹ Lehner, Theo. (2002, September 2). Manager Research and Development, Boliden. Personal interview.

²⁰² The amounts further processed at other smelters depends on the processing costs which tends to fluctuate.

²⁰³ Fuchs, Stefan-Georg. (2002, July 5). Umicore Precious Metals. *Re: Tin/lead solders vs. Alternatives*. E-mail to Ulrika Kindsjö.

the waste could be developed. During the study, some examples of upcoming recycling techniques were identified. In Appendix 4, these recycling techniques are presented.

5.3.3 Economic Implications

Because the metal price for silver is much higher than for tin and lead, the economic incentive for recycling will probably increase if the eutectic tin-lead solder is substituted with silver-containing solders (see Table 5-2). Copper is easily refined with current smelting processes, which, at least, will not make it less beneficial to change to a copper-containing solder.

In Box 5-1, the author has made calculations on the monetary value of one ton of PCBs. As can be seen in the box, the monetary value will increase if the tin-lead solder is substituted with tin-copper (99.3 Sn/0.7 Cu) or tin-silver-copper (95.5 Sn/4.0 Ag/0.5 Cu) solders. The calculations are based upon the monetary value of the amounts of copper, silver and gold contained in PCBs (see Table 4-5) and the amount of the same metals contained in the solders. The value of other metals, e.g. zinc, is excluded as it is assumed that the values of these metals will not make a significant difference. As can be seen in Box 5-1, the monetary value of the PCB fraction containing tin-copper solder is not significantly different from the value of the PCB fraction containing tin-lead. The monetary value for the PCB fraction containing tin-silver-copper will increase with about 7%. Thus, if tin-lead solders are substituted with the tin/silver/copper alloy, the economic incentive for recycling PCBs will increase. However, when making analyses of metal prices and possible effects on the commodity markets, caution is important.²⁰⁴ Moreover, it is important to note that the calculations presented in Box 5-1 are made without incorporating any treatment or processing costs.

Table 5-2. Metal prices and reserves for Bi, Cu, Pb, Ag and Sn.

Metal	World reserves (thousand)	Price (US \$/lb)	Price (US \$/kg)*
Bismuth	260	3.50	7.7
Copper	650 000	0.89	2.0
Lead	140 000	0.44	0.97
Silver	420	76.54	168
Tin	12 000	3.70	8.2
Gold	77	4480	9900

* Calculated by the author based on the prices in US \$/lb, 1 lb = 0.4536 kg.

Source: Turbini 2002.

²⁰⁴ Nimmo, Kay. (2002, June 28). Research Director, Soldertec, Tin Technology Ltd. *Re: Recycling of solders*. E-mail to Ulrika Kindsjö.

Box 5-1. The monetary value of one ton of PCBs, calculated based upon the content of copper, silver and gold. The metal prices used are presented in Table 5-2. Values for PCB fractions containing two percent tin-lead, tin-copper respectively tin-silver-copper are presented. The value for the PCB fraction containing tin-lead solder is based upon the content of copper, silver and gold displayed in Table 4-5. For the two other fractions, the value of the metals contained in the solder is added to the above value.

PCBs containing Sn/Pb solder	= (525 (Cu) + 557 (Ag) + 790 (Au)) US \$/ton = = 1870 US \$/ton
PCBs containing Sn/Cu solder	= ((525+0,27) (Cu) + 557 (Ag) + 790 (Au)) US \$/ton = = 1870 US \$/ton → < 0.01% increase
PCBs containing Sn/Ag/Cu solder	= ((525+0,20) (Cu) + (557+135) (Ag) + 790 (Au)) US \$/ton = = 2000 US \$/ton → 7% increase

In general, it is very difficult to predict metal prices and consequently, it is hard to assess the economic impacts of a lead substitution with any of the alternative metals. Nevertheless, the economic impacts will probably be very crucial to the metal recycling of PCBs. As mentioned before, with current processes, the smelters, except Umicore, do not separate bismuth from the copper cathodes. However, with strong economic incentives, the smelters might add new process steps that can separate bismuth.

5.4 Impacts of Substituting Lead in Solders on Pre-consumer Soldering Recycling

One of the most crucial issues that the solder recycling industry, which processes leftover solder and oxidised solder from the manufacturing and application steps (see Section 4-6), is facing, is the transition period under which leaded solders will be substituted with lead-free alternatives. Dependent on the lifetime of various EEE, this period could last up to decades. What is very crucial for the industry is the classification of lead-free, i.e. what level of lead contamination is acceptable to still call it lead-free. However currently, the RoHS directive does not give a classification of what is meant by lead-free solders.

For the recycling industry, the transition will mean that two different processes, one for leaded and one for lead-free solders, will most likely have to be established as it will be impossible to avoid some contamination of lead-free solders if the processes are kept together.

Without going into any detail of the recycling process of solder, concern about silver and bismuth contamination has also been expressed. This information is currently being collected for the LFSP, however due to the early stage of the LFSP project no further analysis of this information can be made at this point. The reader is instead recommended to read the final project report of the LFSP, which will be published sometime in mid to late 2003.

5.5 Summary of the Possible Implications of the Lead-free Alternatives on Waste EEE Recycling

Table 5-3 gives a summary of the possible implications of substituting tin-lead solders with the lead-free alternatives addressed in this research, on the current recycling system for PCBs.

Table 5-3. Summary of the possible implications of subsisting tin-lead solders with the lead-free alternatives addressed in this study.

Solder Alloys	Environmental Implications	Technical Implications	Economic Implications	Comments
Tin/Lead (63 Sn/37 Pb)	Pb: Highly toxic to humans and the environment Sn: Toxic to humans in high doses; toxic to aquatic species, but low bioavailability	Sn and Pb are not recycled in the copper smelting process*	(-) Processing of filter dust containing Sn and Pb	
Tin/Copper (99.3 Sn/0.7 Cu)	Cu: Low toxicity to humans Sn: Toxic to humans in high doses; toxic to aquatic species, but low bioavailability	High content of Sn is not recycled in the smelting process Cu is refined as an end product	(+) Contains Cu	No problems detected in substituting to this alloy
Tin/Silver/Copper (95.5 Sn/4.0 Ag/0.5 Cu)	Ag: Low toxicity to humans, may cause argyria; toxic to the aquatic environment but low bioavailability Cu: Low toxicity to humans Sn: Toxic to humans in high doses; toxic to aquatic species, but low bioavailability	Sn is not recycled in the smelting process Ag and Cu are refined as end products	++ High content of Ag	Preferred solder, as it will increase the economic incentives for PCB recycling
Tin/Silver/Bismuth (42 Sn/1.0 Ag/57 Bi)	Ag: Low toxicity to humans, may cause argyria; toxic to the aquatic environment but low bioavailability Bi: ?, (lower toxicity than lead) Sn: Toxic to humans in high doses, toxic to aquatic species, but low bioavailability	Sn is not recycled in the smelting process Ag is refined as an end product Bi contaminates the copper cathodes	+ Contains Ag - - High content of Bi	Contains high amount of Bi and should definitely avoided
Tin/Silver/Copper/ Bismuth (92.3 Sn/3.4 Ag/ 1.0 Cu/3.3 Bi)	Ag: Low toxicity to humans, may cause argyria; toxic to the aquatic environment, but low bioavailability Bi: ?, (lower toxicity than lead) Cu: Low toxicity to humans Sn: Toxic to humans in high doses; toxic to aquatic species, but low bioavailability	Sn is not recycled in the smelting process Ag and Cu are refined as end products Bi contaminates the copper cathodes	+ High content of Ag - Contains Bi	Contains Bi and should be avoided, however, since it contains high amounts of Ag it could be possibly that the economic value of Ag could offset the costs of installing separation technologies for Bi

6. Conclusions and Recommendations

The proposal by the European Commission to substitute lead in solders has, during the last year, been extensively debated. One of the arguments against the decision is that it is not based on any risk assessment and thus, there is the potential that lead in solders could actually be substituted with metals that might impose an as big or even bigger environmental threat. During the study, it has been confirmed that no such risk assessment was actually performed prior to the development of the proposal. Instead, the decision to ban lead in solders is predominantly based upon general toxicological and eco-toxicological data about lead. Concerns about current waste management of EEE and the leachability of lead, when EEE waste is deposited in landfills, have also been raised. Additionally, concern about worker's health problems with lead in the recycling of EEE waste has also been raised.

The European Commission's decision to phase out lead in solders can be seen as an implementation of the so-called precautionary principle. The principle, which recognises that scientific certainty often comes too late for the design of proper responses for preventing environmental threats, is defined in article 15 of the Rio Declaration as:²⁰⁵

Where there are threats of serious or irreversible damage, lack of full scientific certainty shall not be used as a reason for postponing cost-effective measures to prevent environmental degradation.

Aware of the significant environmental threats that lead poses, the Commission decided that it was proper to propose a ban on lead in solder without knowing the science of the possible exposure routes to humans and the environment. Gabriellson has expressed that as lead is reproduction-toxic and has bioaccumulation properties, all efforts to phase out lead in various applications should be prioritised before any preventative efforts such as increasing the amounts recycled.²⁰⁶

The knowledge about the toxicity of lead is extensive and there is no doubt that lead is very toxic to both humans and the environment, and thus, should be avoided in production when possible. Currently, approximately 100 000 to 125 000 tons of electronic solders are produced annually, equivalent to 37 000 to 46 000 tons of pure lead.²⁰⁷ Although this lead only accounts for some 0.5% of the total amount of the lead consumed globally, significant amounts of lead is de facto used in today's solders, which if not properly handled could cause harmful effects to both humans and the environment.

Looking at the current state of the RoHS directive, it seems like the probability of a ban of lead in electronic solders is very high. To help the electronics industry adapt to the required changes, the next thing to investigate is the possible implications of a ban on lead in solders. In this thesis, the focus has been on possible implications on the recycling of EEE waste.

Today, there are already many viable lead-free solder substitutes available. In this study four possible alternatives have been studied, i.e., tin-copper (99.3 Sn/0.7 Cu), tin-silver-copper (95.5 Sn/4.0 Ag/0.5 Cu), tin-silver-bismuth (42 Sn/1.0 Ag/57 Bi) and tin-silver-copper-bismuth (92.3 Sn/3.4 Ag/1.0 Cu/3.3 Bi).

In the first step of recycling, the EEE waste is collected and dismantled. Based upon the findings of this study, there seems to be no significant difference in whether tin-lead solders continue to be used or

²⁰⁵ Arvidsson, Ylva. (2001). The Precautionary Principle – Experiences from Implementing into Swedish Law. Lund: IIIEE Master Theses 2001:7.

²⁰⁶ Gabriellson, Göran. (2002, July 12). The Swedish National Chemicals Inspectorate. *Re: Bly i lötlenn* [Lead in solder].

²⁰⁷ Based upon the assumption that all leaded solders used today consist of a 63 percent Sn and 37 percent Pb mixture, which is not completely true.

are replaced with other combinations. However, when the EEE waste is shredded, tin-lead solders might cause some worker health problems, due to lead dust emissions, if the proper precautions are not taken. Based upon this, the author concludes that there might be a small advantage involved in replacing the leaded solders with any of the other lead-free alternatives addressed in this research.

After dismantling, the PCB fractions, which contain considerable quantities of valuable metals, are sold to copper smelters for the recycling of the precious metals and copper. The solder, contained in the PCBs, will follow the pathway of the PCBs. At the copper smelters, most of the tin, lead and bismuth contained in the PCB fractions will be “boiled” away in the process, while silver and copper are refined as separate end products. Tin, lead and bismuth thus follow the process gases and are predominantly trapped in the cleaning devices as filter dust. At the present economic situation, Boliden, which processes almost a third of all EEE waste recycled in the world, subsequently sends approximately one quarter of the filter dust to other smelters for further refinery. However, the remaining three quarters of the filter dust are temporarily stored onsite awaiting final disposal treatment. Consequently, large amounts of raw material resources are lost in the process. From a resource point of view, it could thus, be beneficial to substitute tin-lead solders with solders that contain more silver and copper, since they are currently more effectively recycled.

During the research it was revealed that the problems with leaded solders in today’s recycling process are not so much related to worker’s health and problems with emissions to the environment. Neither are there any technical problems in the recycling process that would require a substitution of lead. Instead, the central important issue is that the tin and lead contained in the solder cannot be recovered in the copper smelting processes as described in this thesis. The question to ask then is if the resource issue, i.e. the loss of raw materials, would be enough to justify a ban on lead in solders. To add a new dimension to this question, it can be questioned whether a ban would actually make any noticeable change at all on the recycling of solders. Looking at the content of silver and copper in the four lead-free solders studied in this thesis, it can be seen that, at the most, these metals will account for 4.5% of the alloy. Thus, in the best case, still 95.5% of the content of the solders will not be recycled by the copper smelters and consequently most of the lead-free solders will also be entrapped as filter dust, which is subsequently deposited. However, as revealed in this study, the substitution to an alloy containing substantially more silver will increase the economic incentives for recycling PCBs and thus, a substitution will silver-containing solders will most likely have resource benefits as well as decreases in human-health and environmental risks.

From interviews with smelter representative and a site visit to Boliden’s copper smelter in Rönnskär, concerns about bismuth, and to some extent tin, in the smelting process were revealed. Some of the bismuth that goes into the process will end up and contaminate the final product i.e. the copper cathode. Since the smelters currently, with the exception for Umicore, have no possibility to separate this bismuth from the cathodes, a possible substitution to bismuth-containing solders could result that the smelter can no longer treat the EEE waste. Today, the smelters are keeping control of how much is fed into the process by sampling all EEE waste for the content of bismuth. If the levels are above a certain amount, the smelters impose penalty fees that the suppliers have to pay. In this study, two alloys containing bismuth were looked upon; one containing 57% bismuth and one 3.3% bismuth, and in both cases these solders could cause significant problems. When it comes to tin, the concerns are not that big today since the amounts of tin in the solder are not too large. However, all the lead-free alternatives, except the tin-silver-bismuth alloy, contain higher amounts of tin and thus, some concern should be raised. To address the issue with tin, the author recommends that investigations of the smelters that process the filter dust should be conducted.

When talking to Boliden representatives about the RoHS directive and the possible ban on lead in solders, they did not see the advantage of, or any reasons, for phasing out lead. They believe that the lead-tin alloy is working fine in their process today and they do not see any environmental or worker’s health problems with lead that would require a ban. However, if the ban is implemented, they would

prefer to see the tin-lead alloy substituted with a copper-zinc-silver, since they can refine all of these metals in their process.

The concern, particularly, about bismuth in alloys has raised the question; what have the smelter operators done to forward their concern to the EU legislatures? When addressing this question to the Boliden representatives, it seems that there is a missing dialogue between the representatives of the smelters and the EU members of parliament. Boliden representatives emphasised that the EU members of parliament do not seem to be interested in their point of view and that they are difficult to contact. With the experience gained during the research, the author wishes to stress that there seems to be a genuine interest, among actors within the electronics industry, for the metal recycling process for EEE waste, however the general knowledge about the processes involved is very limited. Thus, due to deficient knowledge and/or information gaps, the author recommends the copper smelter operators take a more active role and clarify the challenges and opportunities in the recycling chain of EEE waste.

In general, it should also be pointed out that most of the findings in this thesis are based upon the information provided by Boliden and its smelting process. Consequently, more, in depth information about the processes run by the other smelters is needed to verify how representative the findings are for all the smelters. However, based upon the knowledge that Boliden and Noranda use quite similar processes and that they, together, process approximately 80% of all PCB containing waste, the overall findings of this thesis likely give an accurate representation of the current reality in this field. However, specific process data and percentages should be investigated further.

In this thesis, the focus has only been on the recycling of EEE waste, however, still most of the EEE waste will be destined for incineration and landfilling. In general, it can be said that much data about how much EEE waste is generated and the fate of this waste stream are missing and more complete investigations of the current situation needs to be conducted to obtain a full assessment of the possible benefits or risks of substitution lead-based solders with lead-free solders. Perhaps, even more importantly, is the need for fully understanding the dynamics of the recycling system in operation today. In the future, the amounts of EEE waste separately collected for recycling will most likely double, as set by the current collection target of 6 kg per capita, in the WEEE directive. The question to ask then is; will the current system be able to handle all EEE waste? When it comes to the separately collected PCB fractions there seem to be no direct upper limit for how much the copper smelters can process. However, large amount of EEE waste will be low value materials that most likely will have to be processed through more elaborate separating activities than those currently used in order for the materials to be utilised by the copper smelters. Thus, new more efficient separation technologies to, for instance, separate iron, aluminium, wood and organic fractions, will most likely be needed in the future.

To summarise, it can be said that from a recycling perspective, the problems with lead in solders do not seem to be very extensive. If leaded solders are substituted with lead-free alternatives, there seem to be some possible benefits, but also drawbacks, involved. Silver containing solders, e.g. the tin-silver-copper alloy addressed in this study, will increase the economic incentives to recycle PCBs, due to the higher economic value of silver. Consequently, tin-silver-copper alloys would be preferred from a recycling perspective. During the study, no particular problems with the tin-copper alloy were found and thus, a substitution with tin-copper alloys could also work fine. However, when it comes to the bismuth containing alloys, these should be avoided as much as possible, due to the problems that bismuth causes in the copper smelting process.

Finally, it can be concluded that even though the proposal to ban lead in solders is not based on a full risk assessment, the probability of the ban being implemented in the EU is very high. To be able to say anything about whether the European Commission made a proper decision when proposing the ban on lead or not, further investigation of the entire lifecycle of solders has to be conducted. From the findings of this research, it can be concluded that from a pure recycling perspective of PCBs, the environmental, technical and economic impacts of substituting tin-lead solders with lead-free solders

do not seem to be very extensive. There seems to be some negative technical impacts involved in substituting tin-lead solders with bismuth-containing solders that supports that tin-lead solders should not be replaced by tin-silver-bismuth or tin-silver-copper-bismuth alloys. In the same time, there seems to be some positive economical and indirectly environmental impacts, the latter through increased recycling rates, that could support the replacement of the tin-lead solder with tin-silver-copper or tin-copper solder systems.

6.1 Recommendations

The purpose of this thesis has been to look at the current waste management of EEE, to assess possible impacts that the substitution of lead in solders might enforce on the recycling of EEE waste. The recommendations of this study are consequently related to the recycling of EEE and do not in fact incorporate possible impacts and implications that the substitution of lead in solders might impose on the other life-cycle stages.

1. Full assessments of the amounts of EEE waste generated and the current fate these wastes, should be performed. It is essential to establish better reporting systems and to harmonise the definitions for EEE to facilitate the assessment of how much EEE waste is generated and the fate of this waste stream.
2. Tin-lead solders, if replaced, should be substituted with alloys containing metals that could be effectively recycled. Of the solders addressed in this thesis, the tin-silver-copper is the preferred alloy due to the higher market value of silver that will increase the incentive for recycling of PCBs. The second best alternative is the tin-copper alloy.
3. Bismuth containing solders should be avoided, since bismuth contaminates and lowers the purity of copper in the smelting process. If it is concluded that bismuth-containing solders have such benefits that they cannot be replaced by other alloys, thorough investigations of the impacts of bismuth on the recycling activities must be conducted. Additionally, on-going dialogues between producers, legislators and the recycling industry should be performed to ensure that the right economic incentives to change the smelting processes are present, so that copper smelter can continue to process EEE waste.
4. An assessment of the metallurgical network among different smelters should be conducted to better understand the flows of materials among these. By investigating the smelting processes run by the smelters that process the filter dust, containing most of the “boiled” away solders from the copper smelters, a better understanding of the possible, if any, technical implications of tin in solders on the recycling system, can be obtained.
5. Ensure more effective sharing of information among the EU legislators and the product designers, producers, wholesalers, retailers, waste managers and the recycling industry, on a global basis, to facilitate the implementation of the proposed WEEE and RoHS directives.

Bibliography

- Agency for Toxic Substances and Disease Register (ATSDR). (1990). *Toxicological Profile for Copper*. U.S. Public Health Service. pp. 2.12-2.17.
- Agency for Toxic Substances and Disease Register (ATSDR). (1992). *Toxicological Profile for Tin and Tin Compounds*. U.S. Public Health Service.
- Alliance To End Childhood Lead Poisoning (AECLP) & Environmental Defense Fund. (1994). The Global Dimensions of Lead Poisoning. [Online]. Available: http://globalleadnet.org/pdf/Toxicity_of_Lead.pdf [2002, 30 July].
- Arvidsson, Ylva. (2001). The Precautionary Principle – Experiences from Implementing into Swedish Law. Lund: IIIIEE Master Theses 2001:7.
- Ayres, Robert U. Ayres, Leslie W. & Råde, Ingrid. (2002). *The Life Cycle of Copper, its Co-Products and By-Products*. Report for the Mining, Minerals and Sustainable Development (MMSD) project of the International Institute for Environment and Development (IIED).
- Basel Action Network (BAN) & Silicon Valley Toxics Coalition. (2002). *Exporting Harm – The High-Tech Trashing of Asia*.
- Berglund, Christina. (2001). End of Life Treatment Requirements of Materials Content for Electronics. Thesis 2001:15. Stockholm, Industriellt Miljöskydd, Royal Institute of Technology.
- Blackwell, Glenn R. (1999). Integrated Design Using SMT. In: *29th ASEE/IEEE Frontiers in Education Conference*, 3. 13d/12-13d/16.
- Boliden. (2002a). Miljörapport 2001 Rönnskärsverken och Rönnskärs hamn. Compulsory Environmental Report, produced for the inspection authorities.
- Boliden. (2002b). Rönnskär 2002. [Online]. Available: <http://www.boliden.ca/Ronnskar/pdf/Ronnskar2002.pdf> [2002, 20 August].
- Boliden. (2000). New Rönnskär. Company Booklet.
- CECED. (2002). *Initiatives undertaken by EU Member States and Norway and Switzerland to deal with take-back and proper treatment of waste electrical and electronic equipment (WEEE)*. Status report February 2002. Brussels: CECED.
- Chong, L.H., Howell, Keith and Apell, Marc. (2000). *Getting Started in Wavesoldering*. *Electronics Engineer February 2000*. [Online]. Available: http://www.eetasia.com/ART_8800030101.HTM [2002, 28 August].
- Christensen, Frans M. Jørgensen, Tom & Nielsen, Ivan R. (2000). *Environmental and technical characteristics of conductive adhesives versus soldering*. Working Report No 16. Miljøstyrelsen [The Danish Environmental Protection Agency].
- Commission Opinion COM (2002) 354 final. *Opinion of the Commission pursuant to Article 251 (2), third subparagraph, point (c) of the EC Treaty, on the European Parliament's amendments to the Council's common position regarding the proposal for a Directive of the European Parliament and of the Council on the restriction of the use of certain hazardous substances in electrical and electronic equipment*.
- Commission Proposal COM (2000) 347 final. *Proposal for a Directive of the European Parliament and of the Council on waste electrical and electronic equipment, Proposal for a Directive of the European Parliament and of the Council on the restriction of the use of certain hazardous substances in electrical and electronic equipment*.
- Cookson Electronics. (2002). *Soldering Temperatures*. [Online]. Available: http://www.alphametals.com/lead_free/ [2002, 5 September].
- Council Directive 2000/53/EC of 18 September 2000 on end-of life vehicles. OJ L 269/34 21.10.2000. p.34.
- Council Opinion 2000/0158 (COD) of 14 November 2001. *Common Position adopted by the Council with a view to the adoption of a Directive of the European Parliament and of the Council on waste electrical and electronic equipment*. Interinstitutional File. Brussels.
- Danish Environmental Protection Agency. (2000) [Online]. *Statutory Order No. 1012 of November 13, 2000, on Prohibition of Import and Marketing of Products Containing Lead*. [Online]. Available: <http://www.mst.dk/homepage/default.asp?Sub=http://www.mst.dk/chemi/01073300.htm> [2002, 18 August].

Deubzer, O., Griese, H. & Suga, T. (2001). Lead-free Soldering – Future Aspects of Toxicity, Energy and Resource Consumption. *Proceedings EcoDesign 2001: Second International Symposium*. pp. 952-957.

Economic and Social Committee Opinion 2001/C 116/05 of 29 November 2000 on the ‘Proposal for a Directive of the European Parliament and of the Council on Waste Electrical and Electronic Equipment’, and the ‘Proposal for a Directive of the European Parliament and of the Council on the restriction of the use of certain hazardous substances in electrical and electronic equipment’. OJ C116/29 20.4.2001. pp. 38-43.

El-Retur. (2001). *Resultater og Statistikk* [Results and Statistics]. [Online]. Available: <http://www.elretur.no/ElRetur/statisticER.do> [2002, 13 September].

ENDS Environmental Daily. (September 6, 2000). US firms lobby Gore over EU electroscrap plans. Issue 826.

ENDS Environmental Daily. (June 13, 2000). EU electroscrap directive finally proposed. Issue 780.

ENDS Environmental Daily. (September 26, 1997). DGXI planning single electronic waste directive. Issue 153.

Environmental Chemistry. (2002). *Periodic Table of Elements*. [Online]. Available: <http://environmentalchemistry.com/yogi/periodic/index.html> [2002, 20 August].

European Commission. (2002). *Heavy Metals in Waste, Final Report*. Project ENV.E.3/ETU/2000/0058. Denmark: COWI.

European Commission. (2001). *Working paper for a Directive of the European Parliament and of the Council on the Impact on the Environment of Electrical and Electronic Equipment (EEE)*. Version 1.0. February 2001. [Online]. Available: http://europa.eu.int/comm/enterprise/electr_equipment/eee/workdoc.pdf [2002, 19 August].

European Environmental Bureau (EEB). (2001). *Towards Waste-Free Electrical and Electronic Equipment: EEB argumentation paper concerning the proposal for Directives on Waste Electrical and Electronic Equipment and on the Restriction of the use of certain Hazardous Substances in Electrical and Electronic Equipment*. Brussels: EEB.

Graedel, Thomas E. (2002). Material Substitution: a Resource Supply Perspective. *Resources, Conservation and Recycling*, 34, pp. 107-115.

Grønn Hverdag – Miljøheimevernet. (2002). El-returtesten 2002: Kilo el-avfall levert per innbygger i 2001 [Kilogram of EEE waste per capita in 2001]. [Online]. Available: <http://www.gronguide.no/artikkel.php?id=901> [2002, 8 September]

Le Fèvre, Patrick, J.F. (2002). Environmental Issues in Power Electronics (Lead Free). In: *Applied Power Electronics Conference and Exposition. APEC 2002. Seventeenth Annual IEEE, 2002, 1*. pp. 121-125.

Lee, Ning-Cheng. (2002). *Reflow Soldering Processes and Troubleshooting: SMT, BGA, CSP and Flip Chip Technologies*. Woburn: Butterworth-Heinemann.

Lehner, Theo, & Vikdahl, Anders. (1998). Integrated Recycling of Non-ferrous Metals at Boliden Ltd. Rönnskär Smelter. In J.A. Astejoki and R.L., Stephens Sulfide Smelting '98: Current and Future Practices (353-362). The Minerals, Metals & Material Society.

Luoma, Samuel N., Ho, Y. B. & Bryan, G. W. (1995). Fate, Bioavailability and Toxicity of Silver in Estuarine Environments. *Marine Pollution Bulletin*, 31, 1-3, pp. 44-54.

Mark, Frank E. & Lehner, Theo. (2000). *Plastic Recovery from Waste Electrical & Electronic Equipment in Non-Ferrous Metal Processes*. Brussels: Association of Plastics Manufacturers in Europe.

Ministry of Housing, Spatial Planning and the Environment. (2001). Electrical and Electronic Equipment – Waste in the Netherlands. [Online]. Available: http://www2.minvrom.nl/Docs/internationaal/14285_174elericalequipme.pdf [2002, 23 August].

National Electronics Product Stewardship Initiative. (2002). [Online]. Available: <http://ceec.ra.utk.edu/clean/nepsi/index.htm> [2002, 18 August].

National Safety Council. (1999). *Electronic Product Recovery and Recycling Baseline Report – Recycling of selected Electronic Products in the United States*. Washington: National Safety Council's Environmental Health Center.

NEC Electron Devices. (2002). *Semiconductor Device Mount Manual*. [Online]. Available: <http://www.ic.nec.co.jp/pkg/en/mount/index.html> [2002, 30 August].

- Nimmo, Kay. (2002). Review of European Legislation and Lead-free Technology Roadmap. In: *Conference Proceedings from the IPC and JEDEC International Conference on Lead-Free: Electronic Components and Assemblies*, Doubletree Hotel San Jose, 1-2 May 2002. Northbrook: IPC. pp. 17-45.
- Noranda Metallurgy Inc. (?). Noranda Recycling. Company Booklet.
- Norwegian Ministry of the Environment. (1999). *Regulations regarding Scrapped Electrical and Electronic Products*. [Online]. Available: <http://odin.dep.no/md/engelsk/regelverk/lover/022001-200002/index-dok000-b-n-a.html> [2002, 18 August].
- NWPM. (1999). *Regulation for Disposal of Electrical Goods in The Netherlands*. [Online]. Available: http://www.nvmp.nl/html/10_english/01_d_english.htm [2002, 18 August].
- OECD. (1993). *Risk Reduction Monograph No. 1: Lead – Background and National Experience with Reducing Risk*. OCDE/GD(93)67. Paris: OECD.
- Parliament & Council Common Position 2002/C 90 E/02 of 4 December 2001. Common Position with a view to adopting Directive 2002/.../EC of the European Parliament and of the Council of ... on the restriction of the use of certain hazardous substances in electrical and electronic equipment (RoHS). OJ C 90 E/12 16.4.2002. pp. 12-18.
- Pistoia, G., Wiaux, J.-P. & Wolsky, S.P. (2001). *Used Battery Collection and Recycling*. Industrial Chemistry Library, Volume 10. Amsterdam: Elsevier Science B.V.
- Ponsaing, Per & Hansen, Erik. (1995). *Some Issues Related to the Development of a Possible OECD Council Act on Lead*. TemaNord 1995:564. Copenhagen: Nordic Council of Ministers.
- Promosol. (2002). *Lead-Free*. [Online]. Available: <http://www.desab-elektronik.se/prod/promosol/Leadfree11-compresse.pdf> [2002, 20 August].
- Richards, Brian. (2001a). Lead-free soldering – world's apart? National Physical Laboratory. [Online]. Available: <http://www.npl.co.uk/npl/ei/news/epparticle.html> [2002, 30 July].
- Richards, Brian. (2001b). The Reality of Lead-free Soldering. [Online]. Available: <http://www.npl.co.uk/npl/ei/documents/matworld.pdf> [2002, 6 August].
- Rohr, Otto. (2002). Bismuth – the new ecologically green metal for modern lubricating engineering. *Industrial Lubrication and Tribology*, 54, 4. pp. 153-164.
- Royal Forest and Bird Protection Society of New Zealand Inc. (2001). *Lead Shot and Sinkers – Poisoning New Zealand's waterways*. [Online]. Available: http://globalleadnet.org/pdf/Toxicity_of_Lead.pdf [2002, 30 July].
- Smith, Edwin B. (2002). Environmental Impacts and Toxicity of Lead Free Solders – Including Japanese and European Union Regulations. KTEC Electronics. In: *Conference Proceedings from the IPC and JEDEC International Conference on Lead-Free: Electronic Components and Assemblies*, Doubletree Hotel San Jose, 1-2 May 2002. Northbrook: IPC.
- Socolof, Maria L., Overly, Jonathan, Kincaid, Lori E. & Geibig, Jack R. (2001). *Desktop Computer Displays – A Life-cycle Assessment*. Vol. 1. Design for the Environment Computer Display Project. U.S. EPA.
- Staessen, Jan, A., Buchet, Jean-Pierre, Ginocchio, Giuliana, Lauwerys, Robert, R., Lijnen, Paul, Roels, Harry & Fagard, Robert. (1996). Public Health Implications of Environmental Exposure to Cadmium and Lead: an Overview of Epidemiological Studies in Belgium. *Journal of Cardiovascular Risk*, 3, pp. 26-41.
- Stena Technoworld. (2002). Processen [The process]. [Online]. Available: http://www.stenamettall.se/technoworld/processen/index_processen.htm [2002, 20 August].
- Swedish Committee on New Guidelines on Chemical Policy. (2000). Varor utan faror – förslag till genomförande av nya riktlinjer inom kemikaliepolitiken [Non-Hazardous Products – Proposals for Implementation of New Guidelines on Chemicals Policy]. SOU 2000:53. Stockholm.
- Swedish Environmental Protection Agency. (2002). *Samla in, återvinn! Uppföljning av producentansvaret för 2001, men också mycket mer...* [Unofficial translation by the author: Collect, recycle! Follow-up of the producer responsibility in 2001, but also much more...]. Report 5237. Stockholm: Swedish Environmental Protection Agency.
- Swedish Environmental Protection Agency. (2001). *Waste from Electrical and Electronic Equipment – Coming Regulations in Sweden*. [Online]. Available: <http://www.internat.environ.se/index.php3?main=/documents/issues/technic/electric.htm> [2002, 18 August].

- Swedish Environmental Protection Agency. (1995). *Electronic and Electrical Equipment – The Basis for Producer Responsibility*. Report 4406. Stockholm: Swedish Environmental Protection Agency.
- Swedish National Chemicals Inspection (KEMI). (1994a). *Phasing Out Lead and Mercury*. Stockholm: KEMI.
- Swedish National Chemicals Inspectorate (KEMI). (1994b). *Some Uses of Lead and Their Possible Substitutes – the use of lead in electronics, building, materials, weights, metal working, professional fishing, and miscellaneous other applications*. Stockholm: KEMI.
- Swiss Agency for the Environment, Forests and Landscape. (2002). *Die VREG in Kürze - Verordnung über die Rückgabe, die Rücknahme und die Entsorgung elektrischer und elektronischer Geräte*. [Online]. Available: http://www.umwelt-schweiz.ch/imperia/md/content/abfall/vreginfo_d.pdf [2002, 10 September].
- Swiss Agency for the Environment, Forests and Landscape. (1999). *Ordinance on the Return, the Taking Back and the Disposal of Electrical and Electronic Appliances*. [Online]. Available: http://www.buwal.ch/abfall/docu/pdf/e_vreg.pdf [2002, 18 August].
- Taberman, Stig-Olav, Carlsson, Bo, Erichsen, Hanne, Legarth, Jens B., & Gregersen, Johan C. (1995). *Environmental Consequences of Incineration and Landfilling of Waste from Electr(on)ic Equipment*. TemaNord 1995:555. Copenhagen: Nordic Council of Ministers.
- Tiefert, Karl. (2002). Roadblocks to Pb-free Electronics – A Components Manufacturer’s Perspective. In: *Conference Proceedings from the IPC and JEDEC International Conference on Lead-Free: Electronic Components and Assemblies*, Doubletree Hotel San Jose, 1-2 May 2002. Northbrook: IPC. p. 218.
- Tojo, Naoko. (2002). EPR in Practise 1: Legislation for Electrical and Electronic Equipment. Handouts from lecture at the Master Programme in Environmental Management and Policy 2001-2002. IIIIEE. Lund, Sweden. 11March 2002.
- TOXNET. (2002a). *Bismuth Compounds – CASRN: No CAS RN*. [Online]. Available: <http://toxnet.nlm.nih.gov/cgi-bin/sis/search/?.temp/~AAAn0aGpy:1> [2002, 28 August].
- TOXNET. (2002b). *Copper, Elemental - CASRN: 7440-50-8*. [Online]. Available: <http://toxnet.nlm.nih.gov/cgi-bin/sis/search/?.temp/~BAA2fa40N:1> [2002, 28 August].
- TOXNET. (2002c). *Silver - CASRN: 7440-22-4*. [Online]. Available: <http://toxnet.nlm.nih.gov/cgi-bin/sis/search/?.temp/~AAAZUaWHQ:2> [2002, 28 August].
- Trumble, Bill. (1998). Get the Lead Out! New solders rely on lead-free alloys of tin and do away with the toxic component. *IEEE Spectrum*, 35, 5. pp. 55-60.
- Turbini, Laura J. (2002). The Real Environmental Cost of Lead-Free Soldering. In: *Conference Proceedings from the IPC and JEDEC International Conference on Lead-Free: Electronic Components and Assemblies*, Doubletree Hotel San Jose, 1-2 May 2002. Northbrook: IPC.
- Turbini, Laura J. Munie, Gregory C. Bernier, Dennis, Gamalski, Jürgen, & Bergman, David W. (2001). Examining the Environmental Impact of Lead-Free Soldering Alternatives. *IEEE Transactions on electronic packaging manufacturing*, 24, 1.
- U.S. Environmental Protection Agency. (2002). *Municipal Solid Waste in the United States: 2000 Facts and Figures*. [Online]. Available: <http://www.epa.gov/epaoswer/non-hw/muncpl/report-00/report-00.pdf> [2002, 13 August].
- U.S. Environmental Protection Agency. (2001a). *Emergency Planning and Community Right-to-Know Act – Section 313: Guidance for Reporting Releases and Other Waste Management Quantities of Toxic Chemicals: Lead and Lead Compounds*. Washington: U.S. Environmental Protection Agency.
- U.S. Environmental Protection Agency. (2001b). *EPA Announces New Toxic Release Inventory Reporting Requirements for Lead and Lead Compounds*. [Online]. Available: http://www.epa.gov/tri/lawsandregs/lead/pb_fact_sheet.pdf [2002, 13 August].
- U.S. Environmental Protection Agency. (1991). *Silver: Integrated Risk Information System*. [Online]. Available: <http://www.epa.gov/iriswebp/iris/subst/0099.htm> [2002, 28 August].
- The U.S. Senate. (1994). *Lead Exposure Reduction Act S.729. Final passage, as amended. 103rd Congress 2nd session*. [Online]. Available: <http://www.senate.gov/~rpc/rva/1032/1032133.htm> [2002, 18 August].
- Umicore. (2002a). Annual Report 2001.

Umicore. (2002). Environment and Safety Report 2001.

van Rossem, Chris. (2001). Environmental Product Information Flow: Communication of environmental data to facilitate product improvements in the ICT sector. Lund: IIIIEE Master Theses 2001:28.

Zhang, Shunli. (1999). Recycling and Processing of End-of-Life Electric & Electronic Equipment: Fundamentals and Applications. Luleå: University of Technology Doctoral Thesis 1999:21.

Personal Communication

Axelsson, Anders. (2002, September 2). Market Engineer, Arvamet. Personal interview.

Axelsson, Anders. (2002, August 15). Market Engineer, Arvamet. Telephone interview.

Borell, Michael. (2002, September 16). Environmental Manager, Boliden. Telephone interview.

Derek, Frey (djf25@msm.cam.ac.uk). (2002, July 9). Professor at the materials science and metallurgy department, at the University of Cambridge (UK). *Re: Recycling of solder*. E-mail to Ulrika Kindsjö (ulrika.kindsjo@student.iiiee.lu.se).

Eggert, Axel (kflorenz@europarl.eu.int). (2002, August 16). Scientific Co-worker to Mr. Karl-Heinz Florenz, European Parliament. *Re: RoHS directive*. E-mail to Ulrika Kindsjö (ulrika.kindsjo@student.iiiee.lu.se).

Fuchs, Stefan-Georg (Stefan.Fuchs@umicore.com). (2002, July 5). Umicore Precious Metals. *RE: Tin/lead solders vs. Alternatives*. E-mail to Ulrika Kindsjö (ulrika.kindsjo@student.iiiee.lu.se).

Gabrielsson, Göran (Goran.Gabrielsson@kemi.se). (2002, July 12). The Swedish National Chemicals Inspectorate. *Re: Bly i lödtenn* [Lead in solder]. E-mail to Ulrika Kindsjö (ulrika.kindsjo@student.iiiee.lu.se).

Gerhart, Sandra (S.Gerhart@na-ag.com). (2002, August 2). Public Relations, Norddeutsche Affinerie AG. *Re: Recycling of PCB*. E-mail to Ulrika Kindsjö (ulrika.kindsjo@student.iiiee.lu.se).

Henriksson, Hans. (2002, September 13). Purchase of EEE waste, Boliden. Telephone interview.

Henriksson, Hans. (2002, July 5). Purchase of EEE waste, Boliden. Telephone interview.

Jacobsen, Henrik (etcw-hj@MST.DK). (2002, August 19). ETC Data Manager, European Topic Centre on Waste and Material Flows. *Re: Recycling of scrap electronics*. E-mail to Ulrika Kindsjö (ulrika.kindsjo@student.iiiee.lu.se).

Klingbeil, Marianne. (2002, August 13). European Commission, Head of Unit, A2, Consumption and Waste. Letter to Ulrika Kindsjö.

Lehner, Theo. (2002, September 16). Manager Research and Development, Boliden. Telephone interview.

Lehner, Theo. (2002, September 2). Manager Research and Development, Boliden. Personal Interview.

McLoughlin, Aaron. (2002, August 20). European Commission, DG Environment. Telephone Interview.

Nimmo, Kay (kay.nimmo@tintechnology.com). (2002, June 28). Research Director, Soldertec, Tin Technology Ltd. *Re: Recycling of solders*. E-mail to Ulrika Kindsjö (ulrika.kindsjo@student.iiiee.lu.se).

Rusk, Bertil. (2002, August 14). Ragnsell. Telephone interview.

Sjölin, Sverker (2002, August 22). Environment and Process Manager, Stena Technoworld. Telephone interview.

Socolof, Maria. (2002, July 22). Sr. Research Associate, Center for Clean Products and Clean Technologies, University of Tennessee. Personal interview.

Thomas, Cindy (ThomasC@normin.com). (2002, July 10). Manager Recycling, Noranda Inc. *Re: Recycling of electronic scrap*. E-mail to Ulrika Kindsjö (ulrika.kindsjo@student.iiiee.lu.se).

Wesseldijk, Quierine (Quierine.Wesseldijk@umicore.com). (2002, September 6). Manager Raw Materials Supply – Recycling, Umicore Precious Metals. *Re: Smelting process*. E-mail to Ulrika Kindsjö (ulrika.kindsjo@student.iiiee.lu.se).

Abbreviations

AEA	American Electronics Association
CRT	Cathode ray tubes
BCF	Bioconcentration Factor
DfE	Design for the Environment
EEE	Electrical and electronic equipment
EIA	Electronic Industries Alliance
ELV	EU's End-of-life vehicle directive
EP	European Parliament
EPA	Environmental Protection Agency
EPR	Extended Producer Responsibility
IPC	Association Connecting Electronics Industries
JEITA	Japan Electronic and Information Technology Industries Association
KEMI	The Swedish National Chemical Inspectorate
LFSP	Lead-free Solder Project
MEPs	Members of the European Parliament
NEMI	National Electronics Manufacturing Initiative
NGO	Non-governmental organisation
IPC	Institute for Printed Circuits
PBT	Persistent Bioaccumulative Toxic
PCBs	Printed Circuit Boards
PRO	Producer Responsibility Organisation
RoHS	EU Directive on the Restriction of the use of certain hazardous substances in Electrical and Electronic Equipment
SMT	Surface Mount Technology
THT	Through-Hole Technology
TRI	Toxic Release Inventory
WEEE	EU Directive on Waste Electrical and Electronic Equipment

Appendix 1: European Initiatives to Deal with Proper Treatment of Waste EEE

Excerpt from: CECED. (2002). Initiatives undertaken by EU Member States and Norway and Switzerland to deal with take-back and proper treatment of waste electrical and electronic equipment (WEEE). Status report February 2002. Brussels.

Austria	
Entry into force	The legislation entered into force in March 1992 for fluorescent lamps, and in March 1993 for fridges, freezers and air-conditioning units.
Scope	Fluorescent lamps as well as fridges, freezers and air-conditioning units.
Producer responsibility	Producers are responsible to take back waste appliances, while municipalities are responsible for household collection.
Take-back	<p>Producers are required to establish a collection system for the treatment, recycling and disposal of end-of-life products.</p> <p>For end-of-life domestic appliances, <i>Umweltforum Haushalt</i> (UFH) was set up by manufacturers, importers and retailers to manage the take-back system through a series of contracts with waste transport companies and recyclers. UFH services all retailers in Austria.</p> <p>No distinction is made between historical and new product waste.</p> <p>When a household buys a new product, the end-of-life product can be given back to the retailer/supplier free of charge irrespective of brand. Alternatively, the last user may return the end-of-life product to the local authority collection service.</p>
Financing	<p>Financing is collective.</p> <p>At the time of purchase of a fridge, freezer or air-conditioning unit, the consumer pays a visible waste management charge and receives a EUR 7.27 voucher in return as a proof of payment. The value of the voucher is deducted from the actual waste management fee that the consumer must pay when returning the end-of-life product.</p> <p>The waste management fee is market-based. The pre-paid voucher is a fixed amount. Additional waste management fees are subject to market forces as contracted collection and recycling companies have to acquire the end-of-life products competitively.</p>
Collection target	No collection target, but UFH reports annually to the Environment Minister. The collection rate for refrigerators/freezers is about 60% of sales of new products.
Recycling targets	No. The Environment Minister issues treatment standards.
Remarks	UFH has been requested to prepare one single collective take-back system for all domestic appliances, information and communication technology equipment taking account of the special needs of the different sectors but striving to obtain synergies. Eight years of experience with the collective system for fridges/freezers have shown that it is well-accepted by producers, retailers and consumers. A communication campaign by UFH to reduce illegal disposal of WEEE has been very successful and also won awards from the Economics Ministry and by a public TV vote. The government supports the 'shared-responsibility' concept.

Belgium	
Entry into force	The Flemish Decree was adopted on 16 April 1998. The agreement 134 that finally led to a nation-wide system entered into force in July 2001 for household appliances, IT& telecom, consumer electronics. Rules for lightning equipment, toys, control equipment and measuring instruments, other electric and electronic equipment are expected for July 2002.
Scope	Basically, all electrical and electronic appliances which can be used in households, such as domestic/household appliances, consumer electronics, information and communications technology equipment, and others.
Producer responsibility	Producers are responsible for take-back and proper treatment of waste appliances, while municipalities are responsible for household collection.
Take-back	<p>Legislation suggests a collective approach. Every manufacturer/importer has to have its own system or participate in a collective system and the waste management plan of the system has to be approved by the Minister. Some requirements with regard to the organisation are set out in the legislation – e.g. the co-operation with all municipalities, individual systems would have to give a guarantee that no appliances would be within other systems.</p> <p>RECUPEL is a non-profit organisation and was founded by branch associations as an implementing body to manage WEEE take-back collectively. RECUPEL does not separate historical waste from new product waste.</p> <p>Take-back obligation is free of charge on supplier/retailer when the consumer returns appliances. However, this obligation applies only for old-for-new (1:1, according to sales mix). Alternatively, the last user may return the end-of-life product to the local authority collection service, also free-of-charge.</p> <p>Producers are also required to take back WEEE tendered to them, even if they did not manufacture or supply the end-of-life product (though the latter must be similar).</p>
Financing	<p>Collective financing within branches funded via a visible waste management charge or recycling fee that is added to the price of new products sold. The fee is visibly displayed and charged through the distribution chain and at the point of sale.</p> <p>Recycling fees are charged for all products (product groups) put on the market (first selling onto the national market), and are determined and adjusted according to the real collection and recycling cost per product group.</p> <p>RECUPEL periodically calculates collection and recycling costs per product group and charges these costs to its sector divisions. The sector division's affiliated members finance RECUPEL for the services provided.</p> <p>No specific funding provisions required by legislation – but contributions and balances have to be approved by regional authorities.</p>
Collection target	RECUPEL is required to seek to ensure maximum collection, though the system is not responsible for household collection. It is only required to collect and recycle all WEEE tendered to them.
Recycling targets	90% large household appliances, 70% all others, ferrous-metals 95%, non ferrous-metals 95%, and plastics 20% recycling & re-use.
Developments	<p>The agreement remains in force for a period of five years.</p> <p>The recycling fees “shall be modified on the basis of the recyclability of the appliance or group of appliances that are placed on the market”.</p>

Denmark	
Entry into force	The statutory order entered into force in June 1999.
Scope	Electrical and electronic products (excluding refrigeration units containing CFC 11

	and CFC 12), lighting equipment and nickel-cadmium batteries. The exclusion of refrigeration units containing CFC 11 and CFC 12 stems from a 1996 agreement between the branch, municipalities and the Environment Ministry concerning collection and treatment of the end-of-life products. This agreement entered into force on 1 January 1997 and expires not before 30 June 2007. The financing rules governing this special agreement are compliant with the statutory order of June 1999.
Producer responsibility	Main responsibility is with the local authorities. Manufacturers and importers or associations may be granted a permit to take back, free-of-charge to the consumer, their own and similar end-of-life appliances.
Take-back	Local authorities were required to have appropriate collection and recovery systems in place by 1 June 1999. Local authorities collect both historical and new product end-of-life equipment from households and businesses. Existing collection schemes centred upon retailers and distributors can be kept in place. A manufacturer or importer is allowed to take back end-of-life equipment as long as the relevant Danish requirements are complied with – even if recovery is carried out outside Denmark.
Financing	The costs are included in household waste taxes levied by local authorities.
Collection target	None.
Recycling targets	The objective is to recycle 75% of all returned end-of-life equipment. The handling of specific components is specified.
Developments	20 kilogram per inhabitant per year is currently being collected.

Italy	
Entry into force	Decree 22/97 article 44 on durable product waste since 1997. Negotiated agreement draft - as requested by article 44 of the decree – has recently been updated and at present under discussion.
Scope	For both article 44 of the Waste Decree and the draft negotiated agreement, the scope of the legislation is refrigerators, freezers, washing machines, dishwashers and air-conditioners, TV sets and computers.
Producer responsibility	Producers are responsible for take-back and proper treatment of waste appliances collected by retailers, while municipalities are responsible for household collection.
Take-back	According to Decree 22/97 article 44, the last user can return the end-of-life product to the retailer, waste treatment company or collection facilities. If a negotiated agreement is not in place within 3 years of the publication of the decree (i.e. by November 2000), a deposit scheme may be implemented: the consumer would pay at least 10% of the product price extra (no more than EUR 100) when making a new purchase, if he does not return an end-of-life product at the same time. No extra charge if an end-of-life product is returned. Through collectively negotiated agreements, manufacturers and importers take part to collection, recovery, treatment and appropriate disposal of end-of-life products returned to retailers. Under the current draft, a consortium would be set up to manage the collection and recycling of historical end-of-life appliances.
Financing	In the negotiated agreement draft, the financial responsibility will be collective and a visible waste management fee is foreseen for the white goods.
Collection target	In the negotiated agreement draft: for fridges and freezers 1 st year maximum 1 000 000 units; second year maximum 1 400 000. Washing machines and dishwashers: first year maximum 1,000,000 units; second year maximum 1 500 000 units (<i>under discussion</i>).
Recycling targets	Negotiated agreement draft: re-use/recovery targets of 80% of weight for washing machines, 70% of weight for air-conditioners, 68% of weight for fridges and

	freezers and 65% of weight for dishwashers (<i>under discussion</i>).
Observation	There is currently no specific legislation on WEEE. Article 44 of Decree 22/97 (transposing EU Directives on waste, hazardous waste and packaging waste), covers at present some domestic equipment (refrigerators, freezers, washing-machines, dish-washers, air conditioners, TV sets, computers). In January 2002 the Minister proposed a new agreement text.

The Netherlands

Entry into force	The White and Brown Goods Disposal Decree was adopted on 21 April 1998, and entered into force in January 1999 for large appliances and information technology, and in January 2000 for all product categories.
Scope	The regulations cover domestic/household appliances, consumer electronics, information and communications technology equipment and others (i.e. appliances which can be used in households, thus excluding those appliances with business use only).
Producer responsibility	Producers are responsible for take-back and proper treatment of waste appliances.
Take-back	<p>Collective scheme for “white and brown goods”, managed by NVMP (<i>Nederlandse vereniging Vermijdering Metalektro Producten</i>), a non-profit organisation owned by five branch foundations.</p> <p>Manufacturers and importers are legally required to set up and finance take-back and disposal systems. Although they are free to choose in what way they do this, the Environment Minister is entitled to approve the notification²⁰⁸ of the system or of the individual manufacturer/importer’s plan. There is an obligation to take back end-of-life products returned by the last user to retailers and local waste authorities and tendered by them to manufacturer/importer.</p> <p>The system was set up through the voluntary negotiated or “covenant” procedure, and deals with the entire waste stream.</p> <p>When a household or business buys a new product, the old product can be returned to the retailer/supplier free of charge (old-for-new 1:1). Alternatively, the last user may return the end-of-life product to the local authority collection facility, which is responsible for collection from private households.</p> <p>Information and communication equipment is collected and recycled under a differently managed system, known as ICT. ICT applies the principle of individual financial responsibility: firms are billed individually according to actual recycling costs based on sorting to brands at the recycling company. Producers pay for orphans according to their market shares, and manufacturers internalise this into the price of their products. No visible fee is levied.</p>
Financing	<p>The financing of the system is based on collective financial responsibility.</p> <p>Take-back system financed by manufacturers and importers via a recycling contribution (visible fee) on new products sold, displayed and charged at the point of sale.</p>
Collection target	Mentioned in the notification, not in the regulation.
Recovery targets	The regulation does not mention recovery targets. The minimum percentage in the guideline for notification – different according to product category – ranges from 63 to 76 per cent.
Developments	All major international producers participate in the covenant. The scheme runs an extensive communications programme to influence consumer disposal behaviour. Ten per cent of the scheme’s annual budget is devoted to research into eco-design or design for recycling. Implementation of a system of differentiated fees for new products sold according to relative recyclability is currently under consideration.

²⁰⁸ Guideline Disposal of White and Brown Goods Decree – Information for notification procedures, July 1998

	<p>Incineration and landfilling of WEEE is banned.</p> <p>Collection and recycling results in 2000: appr. 65 million kg collected, equivalent to 4 kg/inhabitant (572 000 fridges/freezers; 285 000 other large appliances; 303 000 televisions; total number of pieces was 1 160 446). Recovery targets have been met.</p>
--	---

Norway	
Entry into force	The national legislation, adopted on 16 March 1998, entered into force in July 1999.
Scope	The legislation covers domestic/household appliances, consumer electronics, information and communications technology equipment, and industrial electro-products (cables, tools...).
Producer responsibility	Producers are responsible for the take-back and proper treatment of waste equipment.
Take-back	<p>Take-back of end-of-life appliances is organised by means of a collective system, a voluntary agreement reached between government and industry associations, manufacturers and importers.</p> <p>Three separate companies organise collection and recycling of the three main categories of WEEE: Hvitvareretur AS for household appliances, Elektronikkretur AS for consumer electronic, IT & telecom, toys, medical devices and others, and Renas AS for industrial electro-products, tools, monitoring and control instruments and some other appliances. All three are waste management companies founded by its branch associations. They are non-profit organisations and no dividends are paid to the owners. Hvitvareretur and Elektronikkretur are working together under the name of El Retur both for internal (i.e. within the collection system) and external purposes (e.g. public awareness campaigns)</p> <p>The system does not separate the waste stream into historical and new product waste.</p> <p>The end-of-life product can be given back to the retailer or supplier free-of-charge, irrespective of brand and purchase of a new product (0:1, as long as it concerns a similar product). Alternatively, the last user may return the end-of-life product to the local authority collection facility, also free-of-charge.</p>
Financing	<p>Collective financing within branches, e.g. household appliances and consumer electronic (recycling fee per unit added to the price of new products sold (time of import or first selling to the market)) and IT & Telecommunication (collection and recycling costs for product groups subdivided on market shares).</p> <p>It is recommended (though it remains entirely voluntary) to show the recycling fee as visible fee. Industry is not allowed to impose the visible fee upon retailers, i.e. the requirement to display the charge on the price tag as a separate, visible item. Nevertheless, most retailers have opted to do this.</p> <p>The recycling fees are based on costs determined for 44 product groups and applied in terms of what the actual collection and recycling costs are.</p> <p>For WEEE deposited at municipal collection points, the fee for handling is put on top of the municipal waste fees (<i>El Retur</i> offers containers, pick-up-service from the municipal collection facility).</p>
Collection target	80% take-back and recycling of the defined annual volume agreed upon by the partners for member companies as of July 2004. 100% take-back and recycling as of July 1999 for non-member companies.
Recycling targets	No.
Developments	All major international producers support and participate in the agreement. The scheme runs an extensive communications programme to influence consumer disposal behaviour. The waste management fee has been adjusted downwards several times since the scheme was launched. Implementation of a system of

	differentiated fees for new products sold according to relative recyclability is currently under consideration.
--	---

Portugal

Entry into force	On 30 January 2002, a law 136 was adopted concerning treatment of end-of-life appliances. On December 31st 2003, the system is supposed to be operational, i.e. requirements for selective gathering and recycling of at least 2 kg per inhabitant per year.
Scope	The following appliances are covered: washing machines, dryers, dishwashers, refrigerators, freezer cabinets, cookers, ovens, electric plates, water heaters, (category 1) personal computers (CPU, monitor, keyboard, and mouse), printers, faxes and telephones (including mobile phones), photocopiers, air condition, TV sets (category 2) and lamps containing mercury (category 3).
Producer responsibility	Municipalities are responsible for household collection. Producers are responsible for proper treatment and take-back of waste appliances.
Take-back	An integrated management system – along the lines of the German Duales System Deutschlands system – will have to be set up before end-May 2002. It will take-back free of charge WEEE from final consumers or last owners. The responsibility is shared among producers, retailers and municipalities. Producers are supposed to financially compensate the municipalities to cover all the costs of separate collection of waste. Responsibility for logistics and waste management will be transferred to the non-profit management system set up by the producers under licence of the Environment Minister. The individual approach is given as an alternative. It is specified that individual responsibility may only be granted if at least the same level of results is ensured.
Financing	The law does not mention the possibility to use a visible fee to finance waste management.
Collection target	Yearly 2 kg per resident
Re-use and recycling targets	75% of the weight per home appliance equipment has to be recyclable or re-usable as well as 65% of the weight per EEE category 2 equipment and 50% of the weight per EEE category 3 equipment.

Sweden

Entry into force	The relevant ordinance and guidelines were adopted in April 2000 and entered into force in July 2001.
Scope	Legislation covers domestic/household appliances (including tools and garden equipment), consumer electronics, ICT equipment and office equipment, toys, lighting sources, medical equipment. Accessories and consumables are covered in so far they have an electrical or electronic function. Municipalities are responsible for fridges and freezers.
Producer responsibility	Producers are responsible for take-back and proper treatment of waste appliances.
Take-back	Legislation recognises individual producer responsibility, but allows for collective schemes. A voluntary, negotiated approach has been adopted for implementation. Individual manufacturers who opt for the individual approach are required to submit a plan on how they would deal with their responsibility. Trade associations founded <i>El-Kretsen AB</i> , a non-profit producers service company. Producers and local authorities co-operate voluntarily in a joint programme <i>El-Retur</i> for the recovery of WEEE. No separation is made between historical and new product waste.

	<p>Manufacturers/importers are required to take back free (and regardless of brand, but according to sales mix) any end-of-life product returned by consumers (when purchasing a similar new product (old-for-new)). Otherwise local authorities carry out collection.</p> <p>Retailers/suppliers are obliged to take back 1:1, according to their sales mix in general, but they may “designate a suitable place”. According to the targets of the <i>El-Kretsen/El-Retur</i> agreement retailers are not intended as places for taking over WEEE. Municipal collection facilities or collection facilities of the system take over WEEE from private households or businesses, further collection facilities are under consideration</p>
Financing	<p>Financing is collective, though the principle is implemented differently by the branches:</p> <ul style="list-style-type: none"> - standard: recycling fee per unit put on the market (recycling fees will be determined and adjusted on base of the real costs) - ICT: costs for ICT-WEEE are charged to manufacturer/importer on base of market shares of the previous period - special agreements: fixed annual fee <p>Importers and manufacturers add a special (sometimes visible) waste management charge to their invoices (to cover costs of recovering products that are returned at the time of sale). The provisions of Swedish marketing law require that consumers have to see the total price of a product. It is recommended that the bill says: <i>"Is a member of El-Retur/El-Kretsen. The costs of producer responsibility for electrical and electronic products is included"</i>. In other words, the fee is invisible at the point of sale.</p>
Collection target	The regulation does not mention collection targets though the system suggests high internal targets.
Recycling targets	No, but general guidelines on reports on outputs are required.
Developments	As of 1 July 2001, there is a ban on landfilling, incineration or shredding of WEEE without prior treatment by a certified operator.

Switzerland	
Entry into force	National legislation entered into force on 1 July 1998.
Scope	Household appliances, consumer electronics, office, IT and communication equipment, and other components of WEEE.
Producer responsibility	Yes.
Take-back	<p>Legislation covers mainly obligations to return, take back and treatment of WEEE and regulations concerning permits and export.</p> <p>End-of-life appliances have to be returned (also obligation to hand in for users) to retailers, manufacturers, importers, or collection facilities (no obligation for municipalities – voluntary participation).</p> <p>Retailers are required to take back appliances that are part of their assortment (1:1), manufacturers are required to take back appliances that they have produced or imported (0:1, for own brand, tendered to them).</p> <p>At present, manufacturers and importers are free in the choice of their system, in 2002 a new regulation is planned that will point out the obligation to have an own system or to participate in a system of the branch.</p> <p>Two voluntary collective systems had been started before any law, were accepted by the national authorities and will be expanded in 2002: S.EN.S – system for refrigerator started in 1991 on initiative of branch association – will take on responsibility for all household appliances (large and small), tools in 2002. SWICO-system for “office equipment” had been started in 1994 by the branch association, other branches for graphic industry appliances, telecommunication and mobile phones joined the system the last years. The branch of consumer</p>

	electronics will join the SWICO-system in 2002. SWICO and S.EN.S are expected to co-operate in a joint system called EasyRec - for collection, information...
Financing	<p>Until end of 2001 for refrigerators, retailers take back appliances on payment of EUR 48 under the S.EN.S-system – this financing system will be changed to indirect payment (recycling fee per unit put on the market) within 2002.</p> <p>Within the SWICO-system a recycling fee is charged per unit put on the market. Recycling fees are calculated on base of the list price of products (but minimum prices for charging fees) or per unit.</p> <p>Members of the SWICO-system are supposed to indicate one type of visible fee like extra position on the bill (x SFr) or remark “the price includes an amount of xy SFr disposal fee” or “the price includes the disposal fee according to the SWICO tariff-table”.</p>
Collection target	None.
Recycling targets	No recycling targets, but detailed reports required on input/output.
Observation	Ban on disposal of (landfilling or incineration) WEEE together with municipal waste. Strict regulations concerning export of WEEE or components. According to the Swiss environment agency, the WEEE ordinance has led to a significant increase in recycling. There has also been employment growth in firms equipped to deal with WEEE.

Appendix 2: List of Business Organisations Consulted by the European Commission Between 1994 and 1999 Before Finalising the Proposals for the WEEE and RoHS

Source: The European Commission. (2000). Proposal for a Directive of the European Parliament and of the Council on waste electrical and electronic equipment, Proposal for a Directive of the European Parliament and of the Council on the restriction of the use of certain hazardous substances in electrical and electronic equipment. pp. 36-37.

AEA (American Electronics Association)
AIE (Association Internationale des Entreprises d'Équipement Electrique)
APME (Association of Plastic Manufacturers in Europe)
CECED (Conseil Européen de la Construction Électrodomestique)
CELMA (Federation of National Manufacturers Associations for Luminaires and Electrotechnical Components for Luminaires)
CPIV (Standing Committee of the European Glass Industries)
EACEM (European Association of Consumer Electronics Manufacturers)
ECTEL (European Telecommunications and Professional Electronics Industry)
EECA (European Electronic Component Manufacturers Association)
ELC (European Lighting Companies Federation)
EUROMETAUX (Association Européenne des Métaux)
EPTA (European Power Tool Association)
ETNO (European Public Telecommunications Network Operators' Association)
EUCOMED (European Confederation of Medical Devices Associations)
EUPC (European Plastics Converters)
EUROBIT (European Association of Manufacturers of Business Machines and Information Technology Industry)
EUROPACABLE (European Conference of Associations of Manufacturers of insulated wires and cables)
EURO COMMERCE (European Association of Consumer Electronics Manufacturers)
EVA (European Vending Association)
FEAD (Fédération Européenne des Activités du Déchet)
GPRMC (Groupement Européen des Plastiques Renforcés/Matériaux Composites)
JBCE (Japan Business Council Europe)
ORGALIME (Liaison of European Mechanical, Electrical and Electronic Engineering and Metalworking)
TIE (Toy Industries of Europe)
UEAPME (Union Européenne de l'Artisanat et des Petites et Moyennes Entreprises)
UGAL (Union des Groupements de Commerçants Détaillants Indépendants de l'Europe)

Appendix 3: Flow Map of the Process Steps Involved in Refining Precious Metals and Copper from PCBs

The information is primarily based upon Boliden's process in Rönnskär.

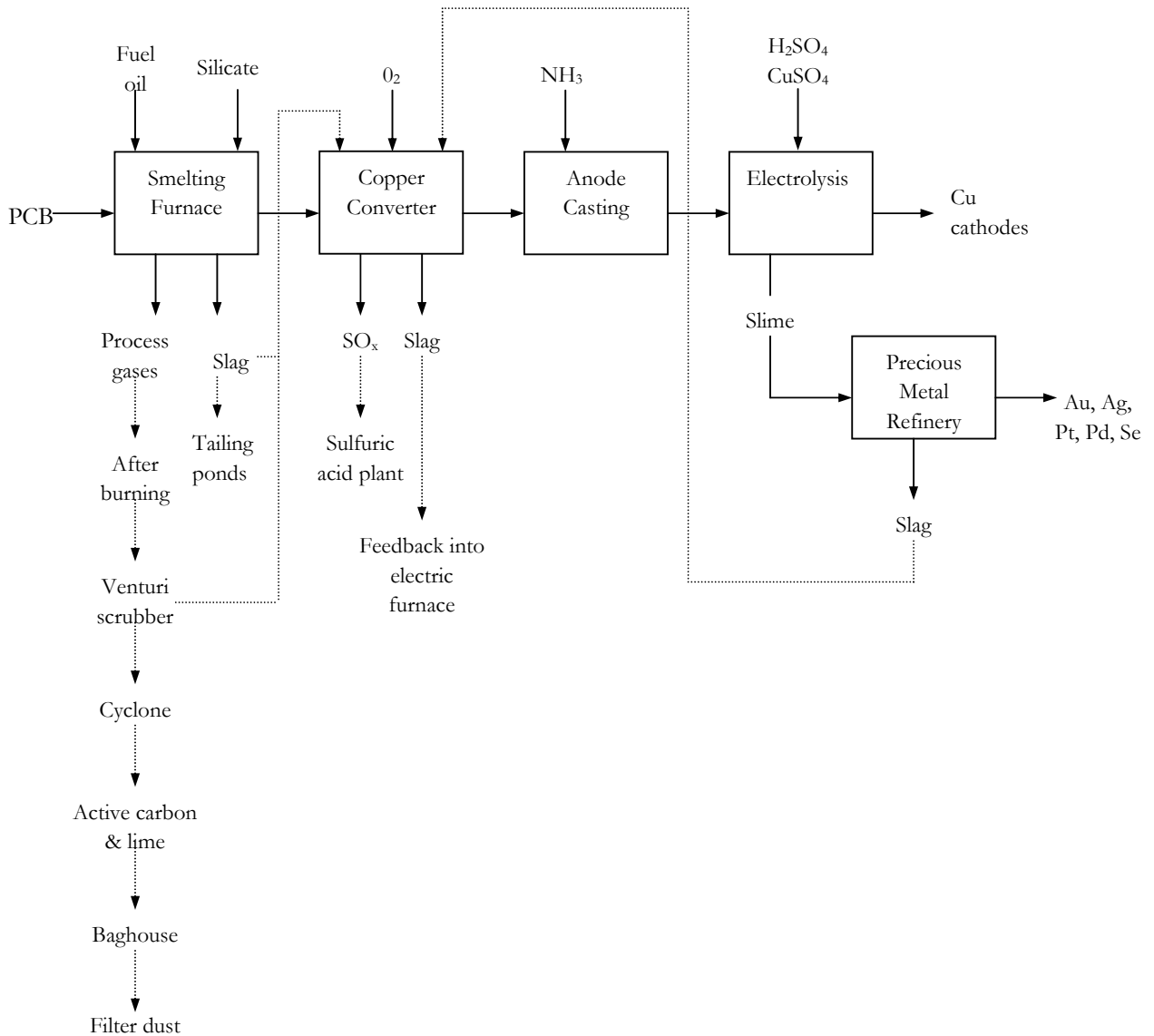

Appendix 4: Possible Future Recycling Technologies for the Recovery of Electronic Solders

Dissolving Solder – Professor Derek Fray

Source: Derek, Frey (djf25@msm.cam.ac.uk). (2002, July 9). Professor at the materials science and metallurgy department, at the University of Cambridge (UK). *Re: Recycling of solder*. E-mail to Ulrika Kindsjö (ulrika.kindsjo@student.iiee.lu.se).

A team of researchers at Cambridge University has developed a process for recycling PCBs that leaves the components ready for reuse. Professor Derek Fray, head of the research, explained that a leaching agent containing fluoroboric acid and titanium ions, Ti^{4+} , is used to dissolve the solder. The components thereafter just fall off the boards. The team is now attempting to find a commercial company to scale-up the process.

Matsushita Recycling System

Source: Business Communications Company (BCC). (2002, January). Matsushita, Solder and Sesame Paste. *Electronic Materials Update*. [Online]. Available: <http://www.buscom.com/letters/emupromo/emu/emu.html> [22 July 2002].

Matsushita has developed a lead-free solder recycling system for the Japanese market that uses sesame seeds. In the soldering process, when the heat-melted solder is applied to the electronic parts, flux will form residues in the leftover solder. Conventional processes use heat or high pressure to separate reusable solder from residue solder. In Matsushita's process, sesame seed paste is added to separate the reusable solder from the waste. The paste, including impurities and flux, is collected at the surface of the solder baths, while the reusable solder is left on the bottom.

Sony's Recovery Process

Source: Yamagiwa, Yasuyuki, Soyama, Shinichi, and Iwata, Shuichi. (2000). Research Concerning the Separation and Recovery of Used Printed Wiring Board Solder. *IEEE Transactions on Electronics Packaging Manufacturing*.

In 2000, Yamagiwa et al. performed tests using experimental equipment to investigate a method of separating and recovering solder from PCBs. Figure 1 shows the fundamentals of the processes. Firstly attached parts such as the frame and wires were removed from the PCBs. Thereafter, the PCBs were attached to a mounting jig and transported by a conveyor belt to a panel heater and hot air heater (see Figure 2). The melted solder on the PCBs, was then separated from the boards by using roll brushes that brushed off the solder. The solder was finally recovered in a receiver.

The experiments that the team of Yamagiwa performed showed that the recovery efficiency of solder increased as the temperature was increased. However, after the temperature of the surface of the PCBs (the side on which components were mounted and the side opposite to the heaters) had reached 198.0 °C the efficiency remained at roughly 90% (see Figure 3).

Yamagiwa et al. also performed chemical composition analysis of solder recovered from scrap TV PCBs and compared the results with the standard composition ISO9453 Sn-Pb solder alloy (60 Sn/40 Pb). It was found that the recovered solder, with regard to nine of thirteen constituents, satisfied the standard levels (see Table 1). However, as the levels of antimony, copper, zinc and cadmium were too high, the recovered solder cannot be used without further purification i.e. electro refining.²⁰⁹

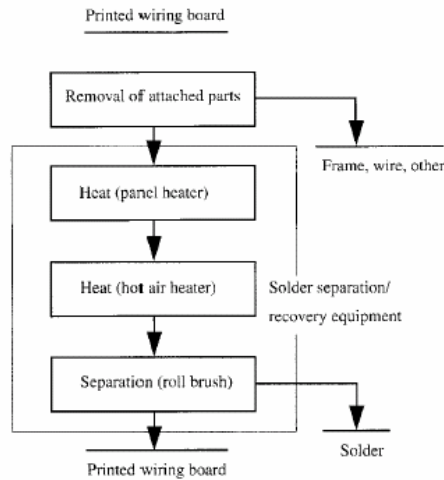

Figure 1. Fundamental description of the solder separation/recovery process. Source: Yamagiwa et al. 2000.

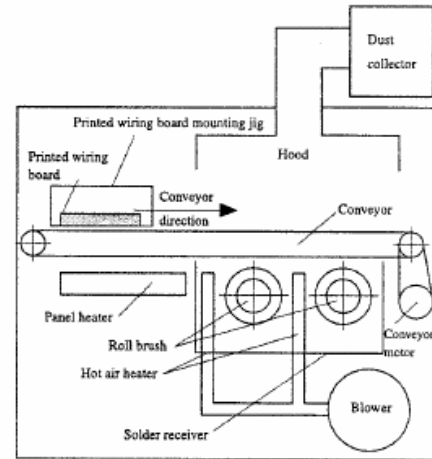
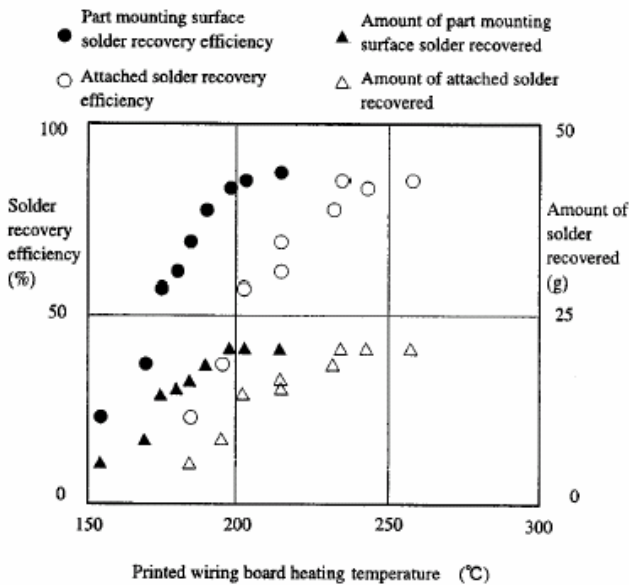

Figure 2. A cross section of the solder separation/recovery equipment used by Yamagiwa et al. Source: Yamagiwa et al. 2000.



²⁰⁹ Yamagiwa, Yasuyuki, Soyama, Shinichi, and Iwata, Shuichi. (2000). Research Concerning the Separation and Recovery of Used Printed Wiring Board Solder. IEEE Transactions on Electronics Packaging Manufacturing.

Figure 3. Relationship between heating and solder recovery efficiency/ amount.
Source: Yamagiwa et al. 2000.

chemical composition.

Table 1. Analysis of recovered solder

Component	Recovered solder analysis results (wt%)	Sn-Pb solder alloy (60 Sn/40 Pb) chemical composition
Sn	60.2	60.0 ± 0.5
Sb	0.19	<0.050
Cu	0.64	<0.050
Bi	0.023	<0.050
Zn	0.002	<0.001
Fe	0.006	<0.020
Al	<0.0005	<0.001
As	0.018	<0.030
Ag	0.040	
Im	0.005	
Cd	<0.010	<0.002
Ni	0.012	
Pb	Remainder (38,8)	Remainder
Impurities		<0.080 Total impurities not including Sb, Cu, Bi

Source: Yamagiwa et al. 2000.